

Owner's Manual & Assembly Instructions

B01

Model No. **EN86-A** **HM86-A** **HM86M**
 MN86-A **NP86** **NW86-A**
 SA86-A **VN86-A**

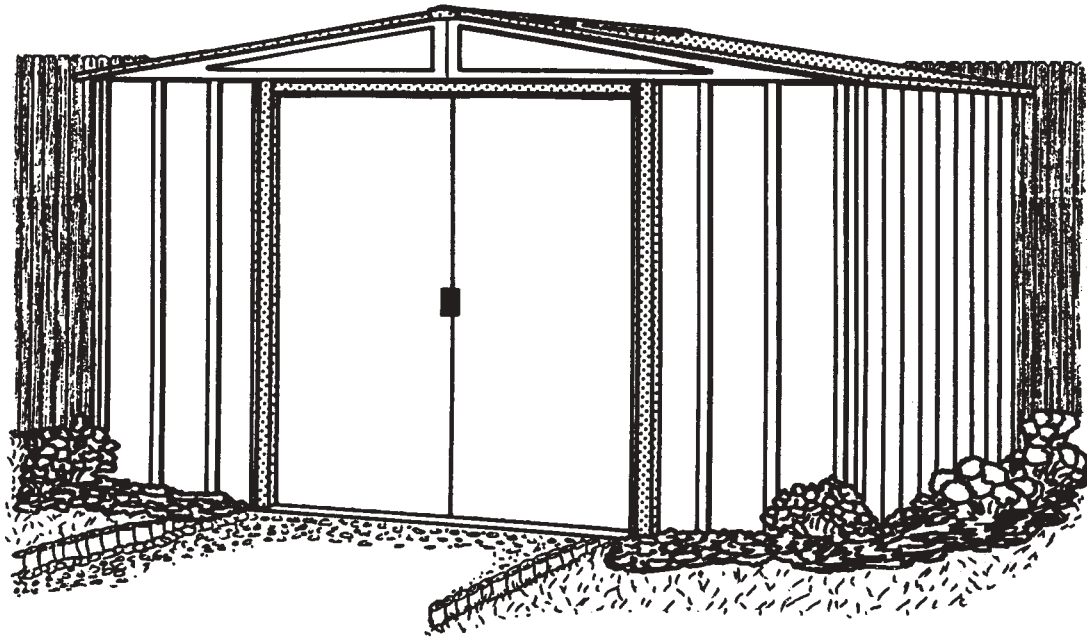

709320506

BUILDING DIMENSIONS * Size rounded off to the nearest foot



CAUTION: SOME PARTS HAVE SHARP EDGES. CARE MUST BE TAKEN WHEN HANDLING THE VARIOUS PIECES TO AVOID A MISHAP. FOR SAFETY SAKE, PLEASE READ SAFETY INFORMATION PROVIDED IN THIS MANUAL BEFORE BEGINNING CONSTRUCTION. WEAR GLOVES WHEN HANDLING METAL PARTS.

*Approx. Size	Foundation Size	Storage Area Sq. Ft. Cu. Ft.		Exterior Dimensions (Roof Edge to Roof Edge)			Interior Dimensions (Wall to Wall)			Door Opening	
				Width	Depth	Height	Width	Depth	Height	Width	Height
8' x 6'	97 1/2" x 68 3/4"	43	230	99 3/4"	71 1/4"	67 7/8"	94 3/4"	66"	66 5/8"	43 1/2"	58"
2,4m x 1,7m	248cm x 175cm	4,0m ²	6,5m ³	253cm	181cm	172cm	241cm	168cm	169cm	110cm	147cm

BEFORE YOU BEGIN....

A2

Owner's Manual

Before beginning construction, check local building codes regarding footings, location and other requirements. Study and understand this owner's manual.

Important information and helpful tips will make your construction easier and more enjoyable.

Assembly Instructions: Instructions are supplied in this manual and contain all appropriate information for your building model. Review all instructions before you begin, and during assembly, follow the step sequence carefully for correct results.

Foundation and Anchoring: Your storage building must be anchored to prevent wind damage. A foundation is also necessary as a base in order to construct a square and level building. Anchoring and foundation materials are not included with your building. We recommend the combined use of an **Arrow Floor Frame Kit** and an **Arrow Anchoring Kit** as an effective method of securing your building to the ground (Available by mail order or at your local dealer) or you may construct a foundation and anchoring system of your choice. Your assembly instructions provide information on a few methods commonly used to secure and level a storage building.

Parts and Parts List: Check to be sure that you have all the necessary parts for your building.

- All part numbers can be found on the parts. All of these numbers (before the -) must agree with the numbers on the parts list. The parts list is located on page 12.

- If you find that a part is missing, include the model number of your building and contact:

Arrow Group Industries, Inc. Customer Service Department
Route 50 East Breese, Illinois 62230
1-800-851-1085

- Separate contents of the carton by the part number while reviewing parts list. The first few steps show how to join related parts to make larger sub assemblies which will be used later.

- Familiarize yourself with the hardware and fasteners for easier use during construction. These are packaged within the carton. Note that extra fasteners have been supplied for your convenience.

PLAN AHEAD...

A3

Watch the Weather: Be sure the day you select to install your building is dry and calm. Do not attempt to assemble your building on a windy day. Be careful on wet or muddy ground.

Teamwork: Whenever possible, two or more people should work together to assemble your building. One person can position parts or panels while the other is able to handle the fasteners and the tools.

Tools and Materials: These are some basic tools and materials you will need for the construction of your building. Decide which method of anchoring and the type of foundation you wish to use in order to form a complete list of the materials you will need.

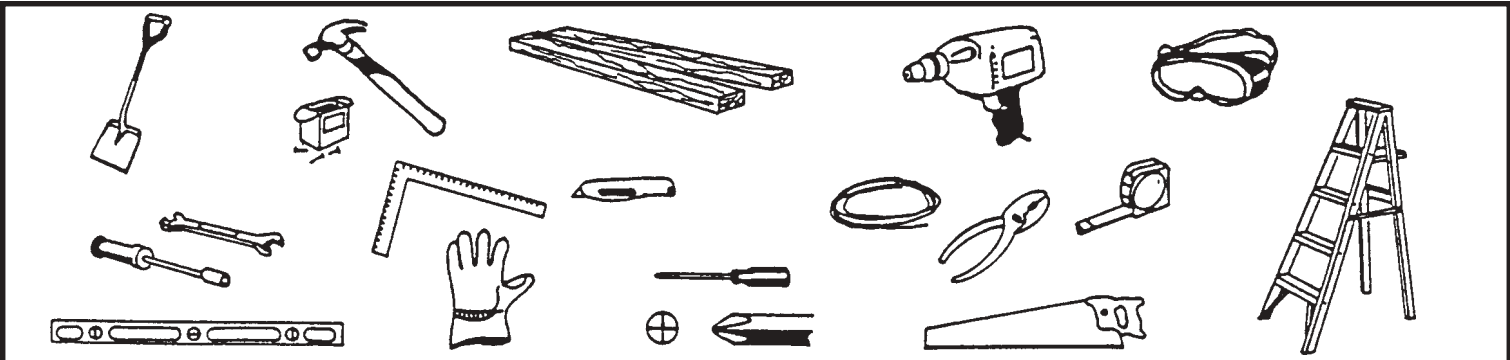

Required	Required	Optional Time-Savers	Foundation Preparation
<ul style="list-style-type: none">• Eye Goggles• No. 2 Phillips Screwdriver (With Hardened Magnetic Tip) Note: A power screwdriver or variable speed drill with Phillips-tip attachment can speed assembly by as much as 40%.	<ul style="list-style-type: none">• Work Gloves• Step Ladder• Utility Knife / Scissors• Pliers• Carpenter's Level• Tape Measure	<ul style="list-style-type: none">• Wrench / Nut Driver• Electric / Cordless Drill• Square• String (for squaring frame)	<ul style="list-style-type: none">• Hammer and Nails• Spade or Shovel• Hand Saw / Power Saw• Lumber and/or Concrete

Selecting and Preparing Your Site: Before assembly, you will want to decide on a location for your building. The best location is a level area with good drainage.

- Allow enough working space for ease of moving parts into position during assembly. Be sure there will be enough space at entrance for doors to open fully and enough space around the building to be able to fasten the panel screws from the outside.

- Before you begin the first steps in assembling your parts, a foundation should be constructed and an anchoring system should be ready to use.

SAFETY FIRST...

A4

Safety precautions are important to follow throughout the construction of your building.

•Care must be taken when handling various pieces of your building since some contain sharp edges. Please wear work gloves, eye protection and long sleeves when assembling or performing any maintenance on your building.

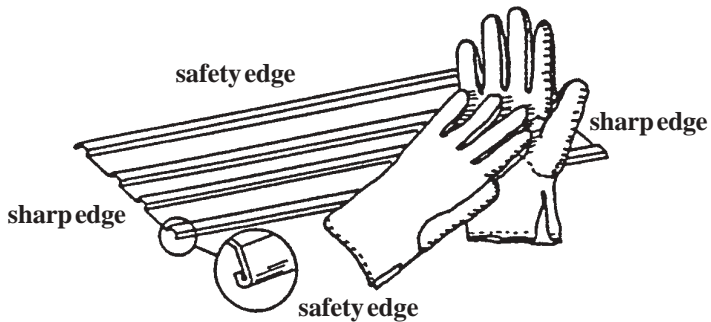

•Keep children and pets away from worksite to avoid distractions and any accidents which may occur.



•Never concentrate your total weight on the roof of the building. When using a step ladder make sure that it is fully open and on even ground before climbing on it.

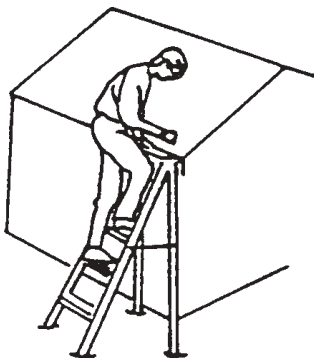

•Practice caution with the tools being used in the assembly of this building. Be familiar with the operation of all power tools.

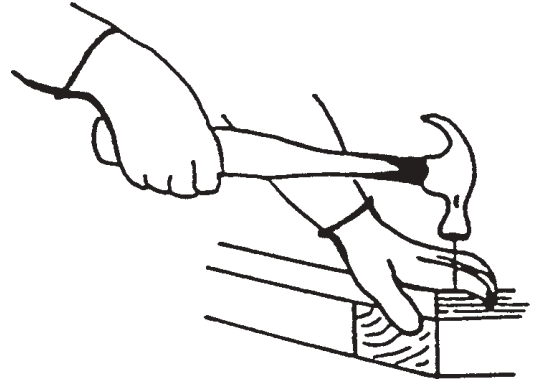

•Do not attempt to assemble the building if parts are missing because any building left partially assembled may be seriously damaged by light winds. Call 1-800-851-1085

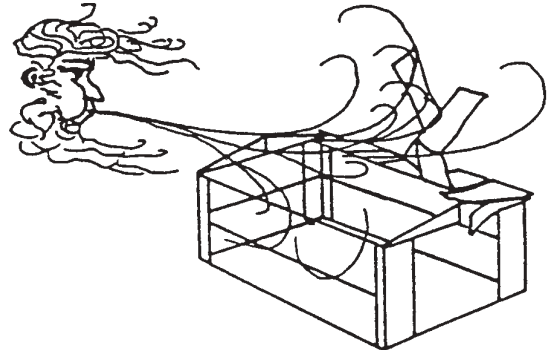

•Do not attempt to assemble the building on a windy day, because the large panels acting as a "sail", can be whipped about by the wind making construction difficult and unsafe.

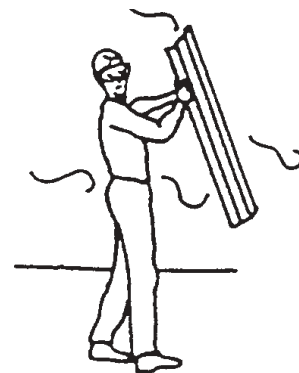

CARE & MAINTENANCE....

A5 Web

Finish: For long lasting finish, periodically clean and wax the exterior surface. Touch-up scratches as soon as you notice them on your unit. Immediately clean the area with a wire brush; wash it and apply touch-up paint per manufacturer's recommendation.

Roof: Keep roof clear of leaves and snow with long handled, soft-bristled broom. Heavy amounts of snow on roof can damage building making it unsafe to enter. In snow country, Roof Strengthening Kits are available for most Arrow Buildings for added protection against heavy snow accumulation.

Doors: Always keep the door tracks clear of dirt and other debris that prevent them from sliding easily. Lubricate door track annually with furniture polish or silicone spray. Keep doors closed and locked to prevent wind damage.

Fasteners: Use all washers supplied to protect against weather infiltration and to protect the metal from being scratched by screws. Regularly check your building for loose screws, bolts, nuts, etc. and retighten them as necessary.

Moisture: A plastic sheet (vapor barrier) placed under the entire floor area with good ventilation will reduce condensation.

Other Tips....

- Wash off inked part numbers on coated panels with soap and water.
- Silicone caulking may be used for watertight seals throughout the building.

Do not store swimming pool chemicals in your building. Combustibles and corrosives must be stored in air tight approved containers.

Keep this Owner's Manual and Assembly Instructions for future reference.

ACCESSORIES...

A6 WEB

ROOF STRENGTHENING (heavy snow load) KITS

Extra roof beams and gable braces designed for added protection against heavy snow accumulation. Increases the strength of your roof by 50%.

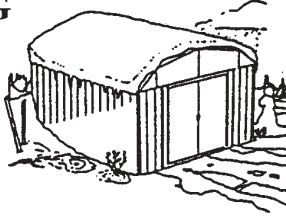

ANCHOR KITS

Model No. AK4

Anchor Kit contains heavy-duty steel augers, 60' (18m) of steel cable and 4 cable clamps. No digging or concrete pouring, just insert cable under roof, over roof beams, into augers and twist augers into the ground. For buildings larger than 10'x9', use 2 kits.

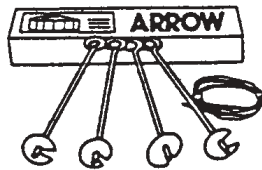

Model No. AK100

New concrete anchor system permits anchoring any size Arrow building directly to a concrete slab. Each kit contains heavy-duty, hot-dipped galvanized steel corner gussets and perimeter clips which fit over the floor frame and lag bolt into a concrete slab. Full assembly instructions and a 1/4" masonry drill bit are included.

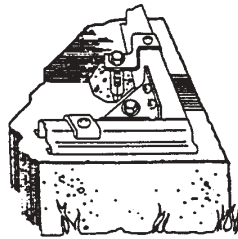

Model No. AK600

Earth Anchor Kit anchors any size Arrow building to the ground. Each kit contains heavy duty, hot-dipped galvanized steel corner gussets and 4 earth anchors.

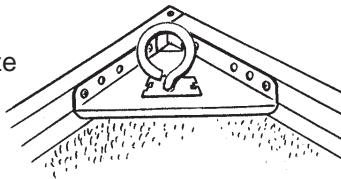

TOOL HANGING RACK

Model No. TH100

The perfect tool organizer. Twin 25 1/2" (65cm) steel channels plus five heavy-duty snap-in hangers and a small tool holder for screwdrivers, pliers, etc. Holders slide along channel for fully adjustable spacing. Great for garage, basement, or the back of any door. Fits all Arrow storage buildings.

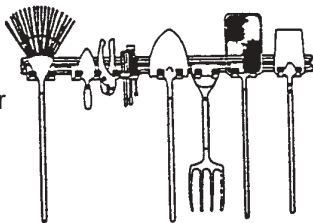

FLOOR FRAME KITS

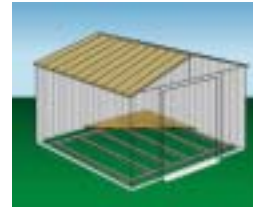

MODELS FB47410, FB5465, FB106-A
FB109-A and FB1014-A

A simple new floor frame system made of heavy-duty, hot-dipped galvanized steel. Use as foundation for plywood, sand or stone.

ATTIC KIT / WORKBENCH KIT

Heavy-duty galvanized steel bars that fit all 10' wide Arrow buildings. They install quickly and easily to help organize space and create more useable space as an attic or workbench. Will hold up to 250 lbs. (113kg) evenly distributed.



Model No.	Fits	Shipping Weight
AT101	10' Long, 250 lb. (113kg) load+ Fits all Arrow 10' wide buildings.	16 lbs. (7kg)

Must be drilled for use as workbench in Estator.
+ Even weight distribution.

SHELF UNITS

Heavy-duty, galvanized steel shelf units help organize storage space. They easily mount on the wall or sit on the floor. Fits all Arrow buildings.*

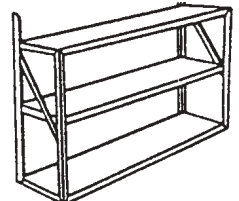
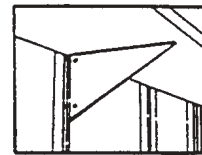
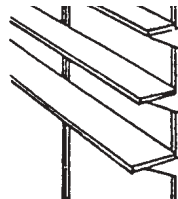

Model No. SS404

- Makes 8" to 12" (20-30cm) wide shelves in any length.
- Brackets, braces, hardware included. Lumber is not included.

Model No. SS900-A

- Grey color
- 3 shelves
- Holds up to 85 lbs. (38kg) (even weight distribution)

* Some drilling required to fit buildings without mid-wall bracing.

THIS
PAGE
WAS
LEFT
BLANK
INTENTIONALLY

THIS
PAGE
WAS
LEFT
BLANK
INTENTIONALLY

Foundation

B9

The Foundation For Your Building

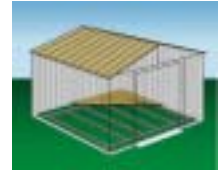

OPTION 1: ARROW FLOOR FRAME KIT: (Order No. FB106-A or 68381-A)

Arrow has the best base for your building in this simple kit. It keeps stored items above the ground. This kit should be used with one of the following:

A. To support a plywood deck **B.** To be filled with sand. We recommend the combined use of **1. an ARROW FLOOR FRAME KIT** and **2. an ARROW ANCHORING KIT** as an effective method of securing the building to the ground. **Allow 1 - 2 hours for construction.**

OPTION 2: Wood Platform

If you decide to build your own foundation, be sure to select the appropriate materials.

These are the recommended materials for your foundation:

- 2 x 4's (5cm x 10cm) Pressure Treated Lumber
- 5/8" (1,5cm) 4 x 8 (122cm x 244cm) Plywood-exterior grade
- 10 & 4 penny Galvanized Nails
- Concrete Blocks (optional)

The platform should be level and flat (free of bumps, ridges etc.) to provide good support for the building. The necessary materials may be obtained from your local lumber yard.

To construct the foundation follow instructions and diagram.

Construct frame (using 10 penny galvanized nails)

Measure 16"/24" (40,6cm/61cm) sections to construct inside frame (see diagram)

Secure plywood to frame (using 4 penny galvanized nails)

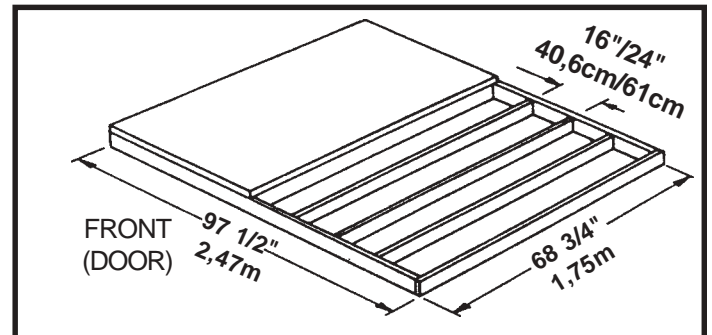

Allow 6 - 7 hours for construction.

Note: Platform/Slab will extend 9/16" (1,4cm) beyond floor frame on all four sides. Seal this 9/16" of wood with a roofing cement (not included), or bevel this 9/16" of concrete when pouring, for good water drainage.

OPTION 3: Concrete Slab

The slab should be at least 3" to 4" (8-10cm) thick. It must be level and flat to provide good support for the frame.

The following are the recommended materials for your foundation.

- 1 x 4's (2,5cm x 10cm) (will be removed once the concrete cures)
- Concrete
- Sheet of 6 mil plastic
- We recommend for a proper strength concrete to use a mix of:
1 part cement ● 3 parts pea sized gravel ● 2 1/2 parts clean sand

Prepare the Site/Construct a Foundation

1. Dig a square, 6" (15cm) deep into the ground (remove grass).
2. Fill up to 4" (10cm) in the square with gravel and tamp firm.
3. Cover gravel with a sheet of 6 mil plastic.
4. Construct a wood frame using four planks of 1x4 (2,5cm x 10cm) lumber.
5. Pour in concrete to fill in the hole and the frame giving a total of 4" (8-10cm) thick concrete. Be sure surface is level.

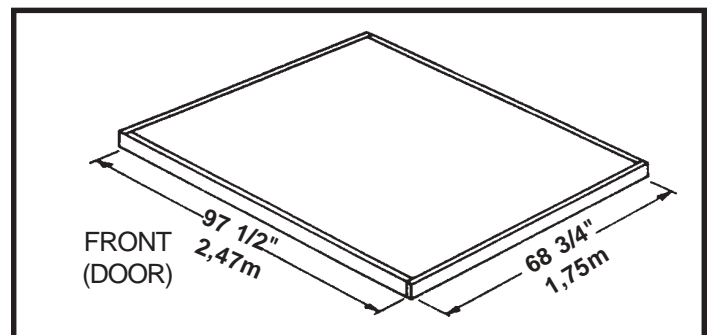

Note: Finished Slab dimensions, with lumber removed.

Allow 3 - 5 hours for construction and a week for concrete curing time.

Anchoring

A10

Anchoring Down The Building

It is important that the entire floor frame be anchored after the building is erected.

Below are recommended ways of anchoring.

Arrow Anchoring Kit: (Model No. AK4 or 60298)

Recommended for use with **any** suggested **base**.

Contains: 4 Anchors with Cable, Clamps and installation instruction.

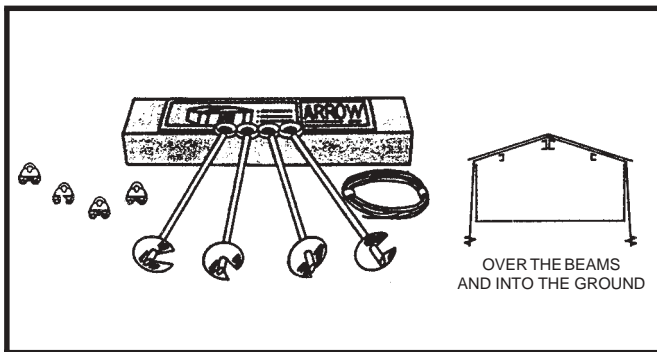

Anchoring into Wood/Post:

Use 1/4" Wood Screws. There are 1/4" (0,63cm) dia. holes provided in the frames for proper anchoring.

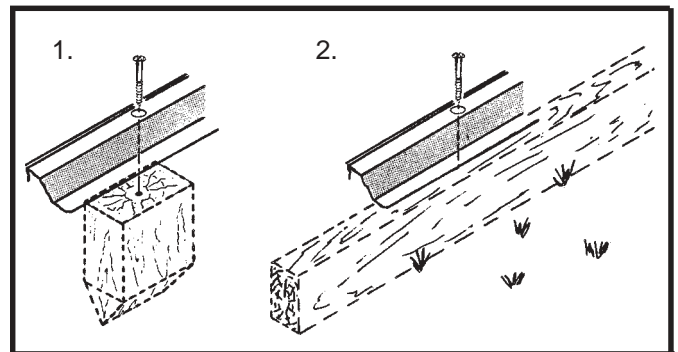

Arrow Anchoring Kit: (Model No. AK100 or 68383)

Recommended for use with the **concrete** foundation.

Contains: Corner gussets, perimeter clips, hardware, 1/4" masonry drill bit and installation instruction.

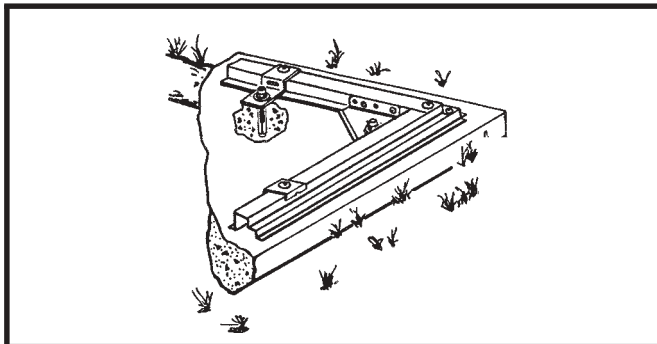

Anchoring into Concrete:

1. For poured concrete slab or footing or patio blocks:

Use 1/4" x 2" Lag Screws.

2. For Anchor Post of Concrete poured after building is erected:

Use 1/4" x 6" Lag Screws.

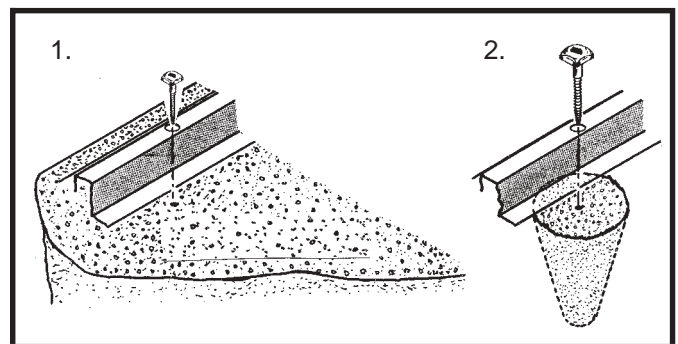

Hardware

B11

Remove from bag of screws
and save for the last step



65103
#8-32 Hex Nut (100)



65900A
#10Bx1/2" Black Screw (4)
(Packed with Screws)



65923
#8-32x3/8" Bolt (100)



65004
#8Ax5/16" Screw (266)

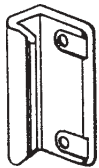

66045
Handle (2)

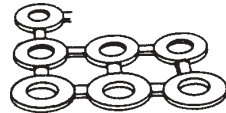

66646
Washer (275)
(8 sheets of 40)



65109
#8-32 Acorn Nut (6)
(Packed with Screws)

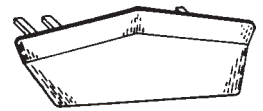

67468
Peak Cap (2)
(Arrow Logo)

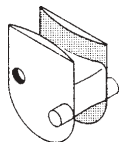

66242
Door Slide (4)

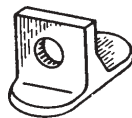

66382
Lower Door Guide (4)

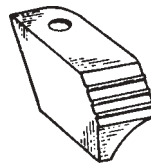

66183
Roof Trim Cap
(2 right & 2 left)

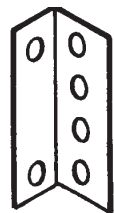

7916
Roof Beam Bracket (4)

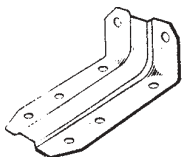

6228
Track Support (2)



66029
Plug (2)
(Packed with Screws)

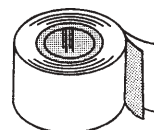

67293
Weather Stripping (1)

Parts List

B12

Assembly Key No.	Part Number	Part Description	Quantity in Carton	Check List
1	6615	Rear Wall Angle	2	
2	6617	Door Track Splice	1	
3	6622	Horizontal Door Brace	4	
4	6658	Gable Brace	2	
5	7875	Roof Panel	4	
6	7906	Right Gable	2	
7	7907	Left Gable	2	
8	8461	Ridge Cap	1	
9	8466	Right Roof Panel	2	
10	8467	Left Roof Panel	2	
11	8474	Roof Beam	3	
12	8476	Side Wall Angle	3	
13	9920	Side Wall Channel	2	
14	8482	Side Roof Trim	2	
15	8941	Ramp	1	
16	8946	Side Floor Frame	2	
17	8995	Wall Panel	4	
18	9355	Vertical Door Brace	2	
19	9358	Right Door	1	
20	9359	Left Door	1	
21	9363	Wall Panel	2	
22	9900	Door Jamb	2	
23	9924	Rear Wall Channel	2	
24	9377	Rear Floor Frame	2	
25	9378	Door Track	2	
26	9379	Front Floor Frame	2	
27	9380	Front Corner Panel	2	
28	9384	Rear Corner Panel	2	

Assembly by Key No.

B13

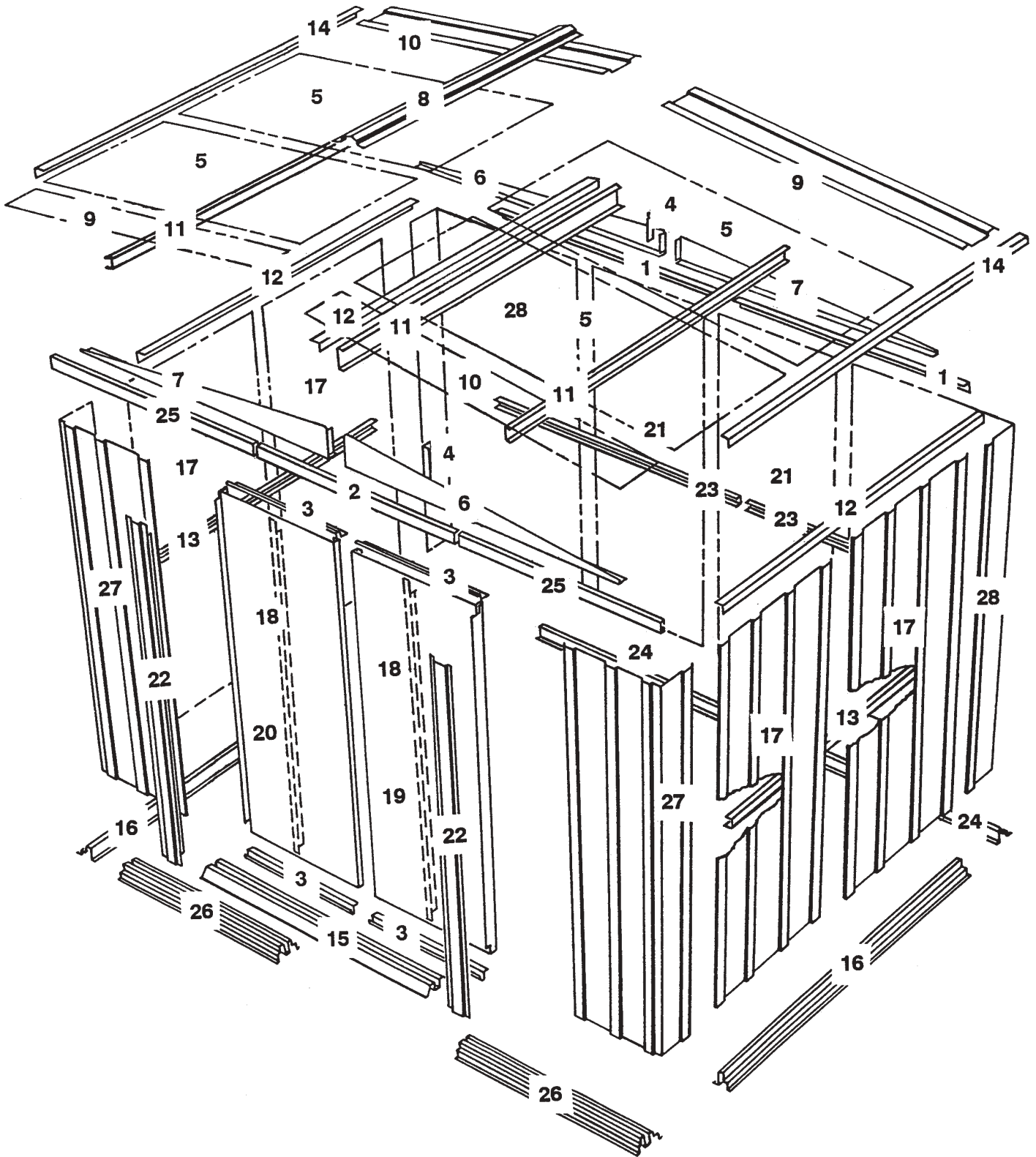

Step 1

B14

● Parts Needed For ● Floor Frame Assemblies

- 8941 Ramp (1)
- 9379 Front Floor Frame (2)
- 9377 Rear Floor Frame (2)

The front floor frame is made up of three pieces. The rear floor frame is made up of two pieces. The holes in these pieces will align when the pieces are positioned with correct amount of overlap. The illustrations below show the proper overall length for the front and rear. Proceed as follows:

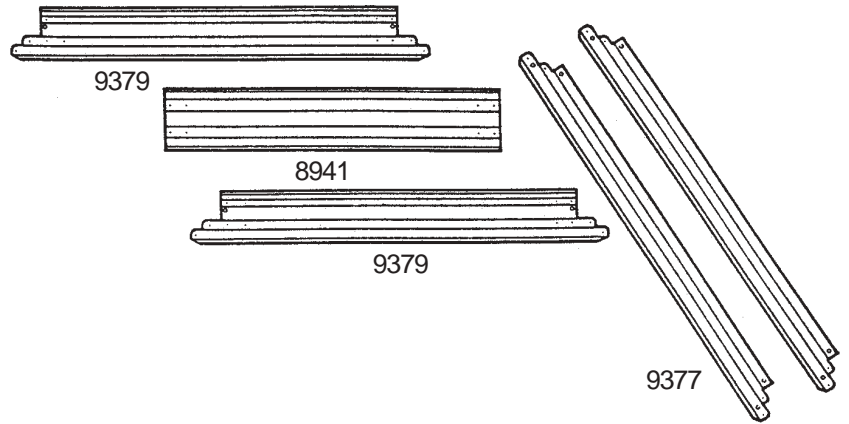

1 Place the **front floor frames** as shown. Center the **ramp**, with drain holes facing outside, on top of the two front floor frames. Join the frames by inserting eight screws.

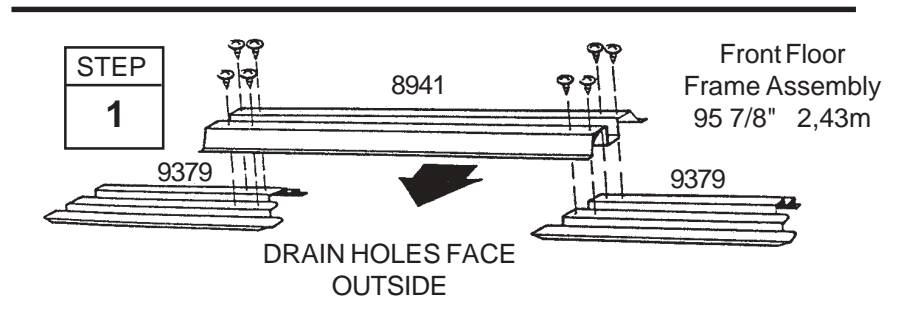

2 Overlap the **rear floor frames** as shown. The holes in these pieces will align when the pieces are positioned with correct amount of overlap. See the illustrations below for the proper overall length of the rear floor frame. Join the frames by inserting five bolts into frame set as shown.

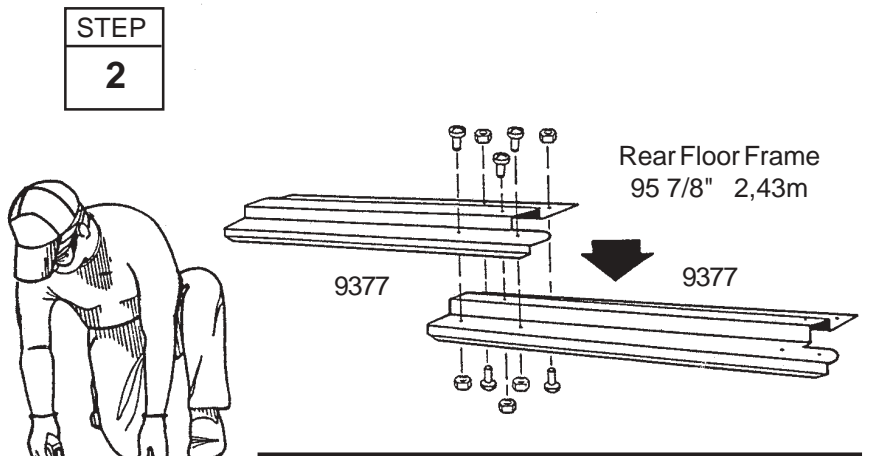

3 Double check the length of each and set these pieces aside for later use.

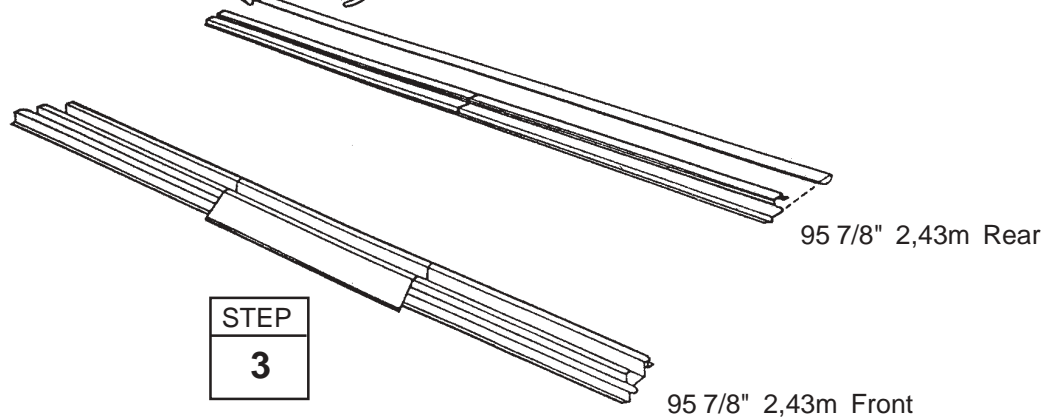

Step 2

B15

● Parts Needed For ● Frame Assemblies

- 6615 Rear Wall Angle (2)
- 9924 Rear Wall Channel (2)

The main frame pieces reinforce the walls. These pieces will later be installed in the center and at the top edge of the rear wall. Proceed as follows:

1 Overlap the **rear wall channel** pieces as shown in the figure and fasten the two pieces together with *one bolt in the center hole* (three holes will align).

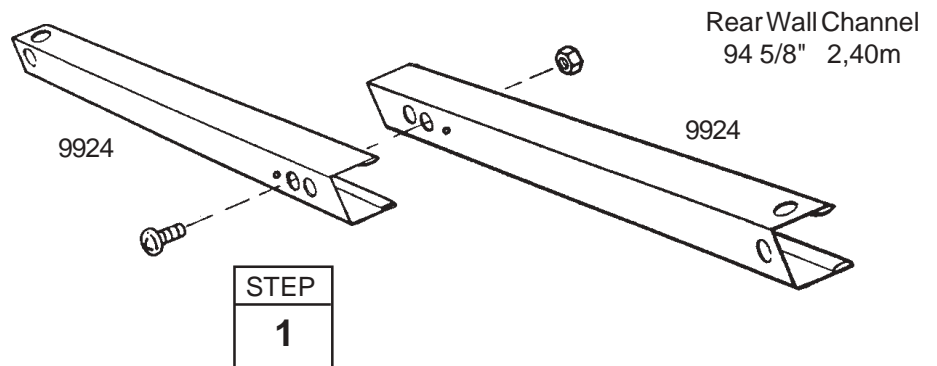

2 Overlap the **rear wall angle** pieces as shown in the figure and fasten them together with *one bolt in the center hole*.

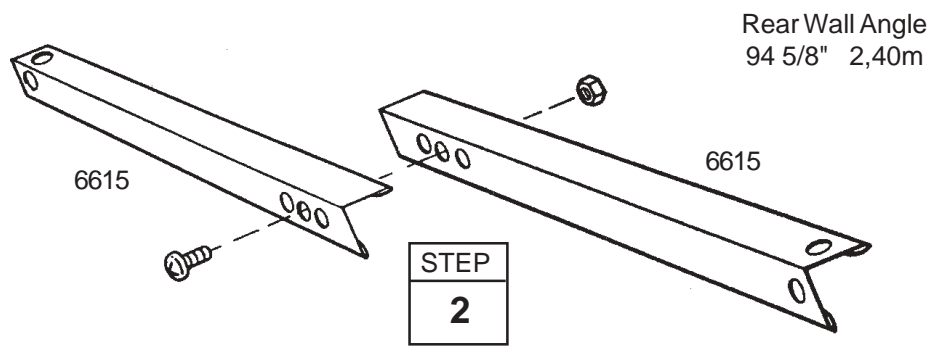

3 Set the assemblies aside. You will use them later.

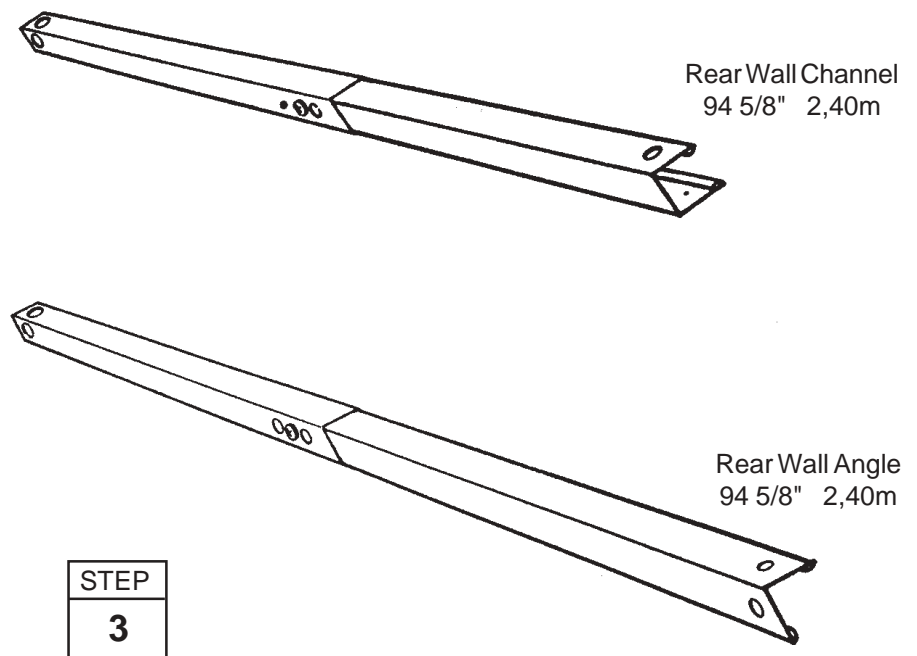

Step 3

B16

● Parts Needed For ● Roof Beam Assembly

- 8474 Roof Beam (1)
- 8476 Side Wall Angle (1)

The roof beams join the two gables and support the roof panels. The main roof beam is made up of two pieces fastened together.

1 Place the **side wall angle**, back-to-back, with a **roof beam** and fasten together using ten screws.

2 Set this piece aside for later use.

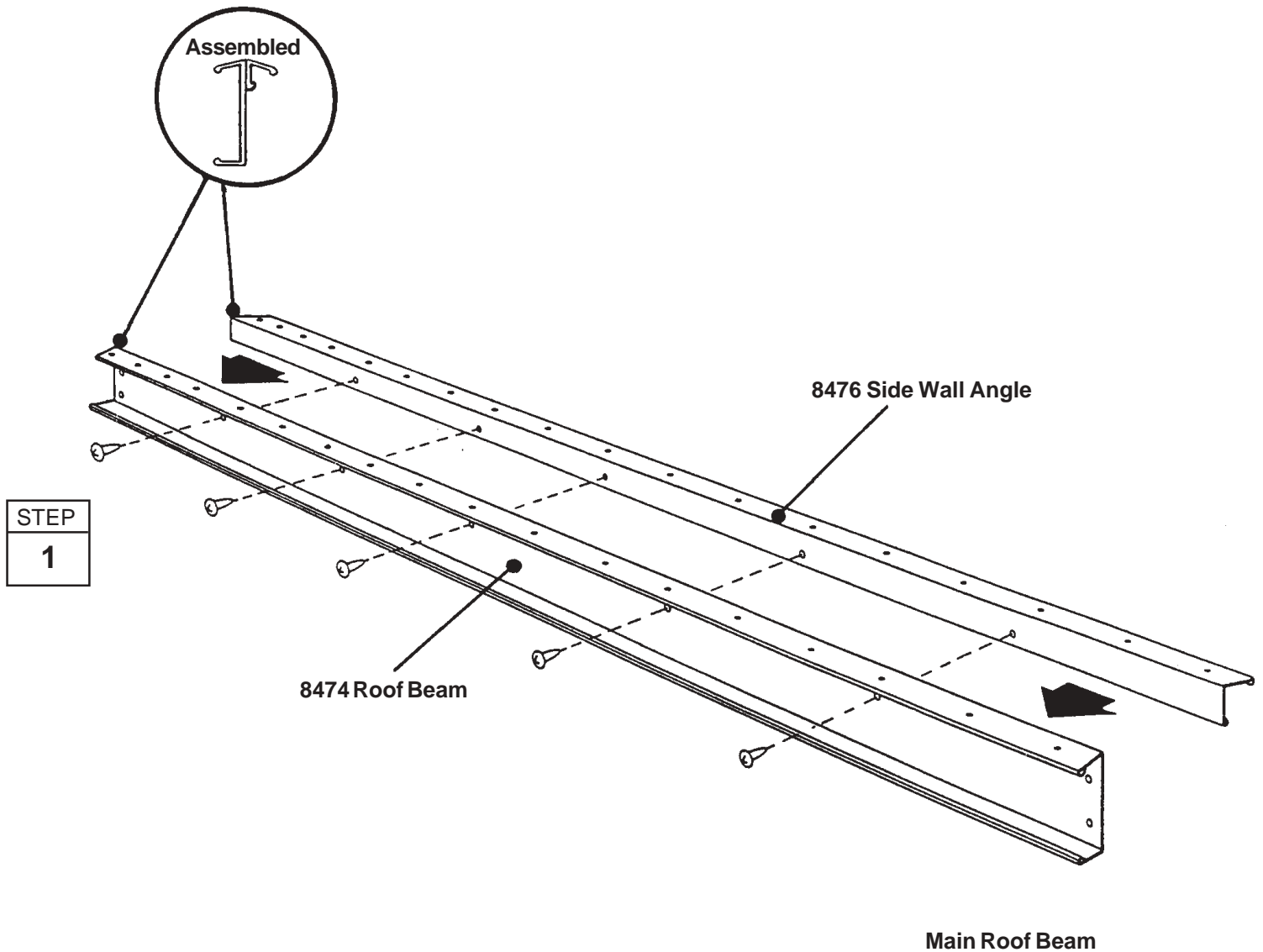

Step 4

B17

● Parts Needed For ● Door Track Assembly

- 6617 Door Track Splice (1)
- 9378 Door Track (2)

The door track assembly supports the sliding doors and reinforces the front wall. It is made up of three pieces.

1 Using the **door track splice**, (painted), join the **door track** (galvanized) pieces end-to-end as shown.

2 Insert four screws *from the underside only*.

Hint: The holes in the top side of the door track assembly are for fastening the gable to the top of the front wall in a later step.

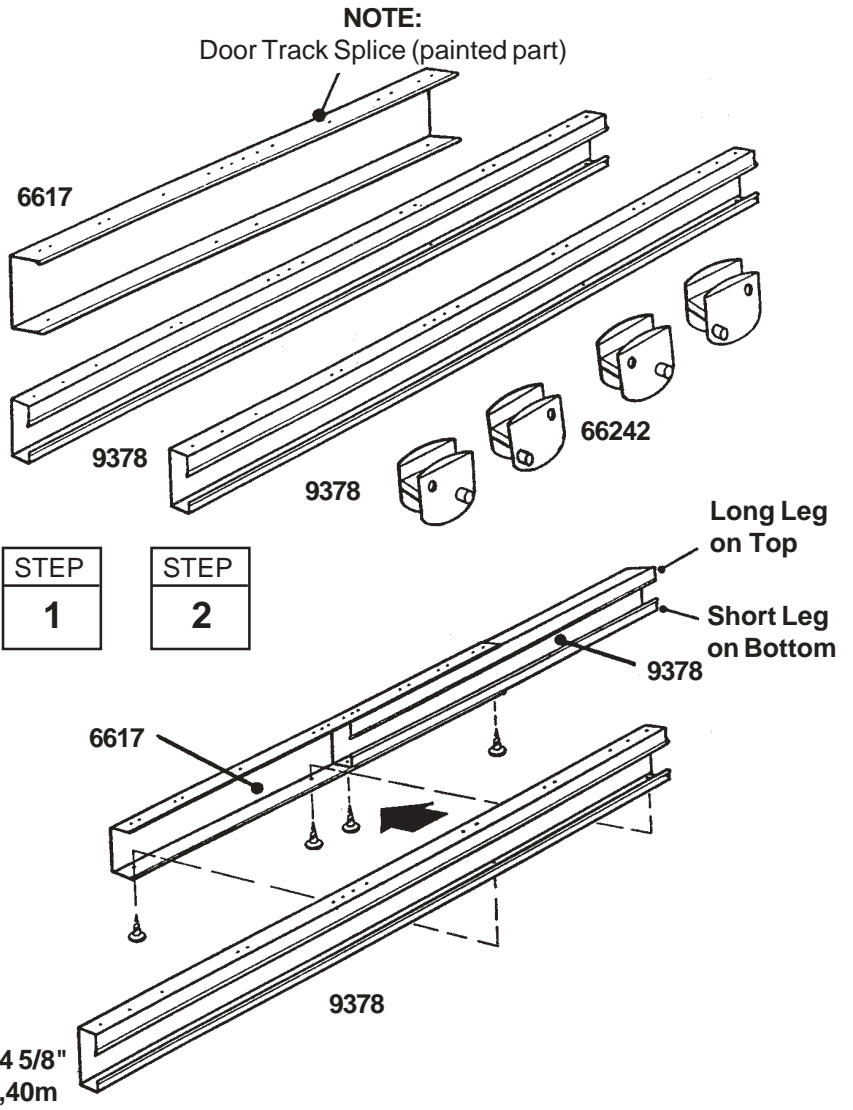

3 Position **door slides** onto the legs, from the end of door track assembly, as shown in the end view. **NOTE:** Flat side on top, pins and holes **must** be oriented as shown.

4 Set this piece aside for later use.

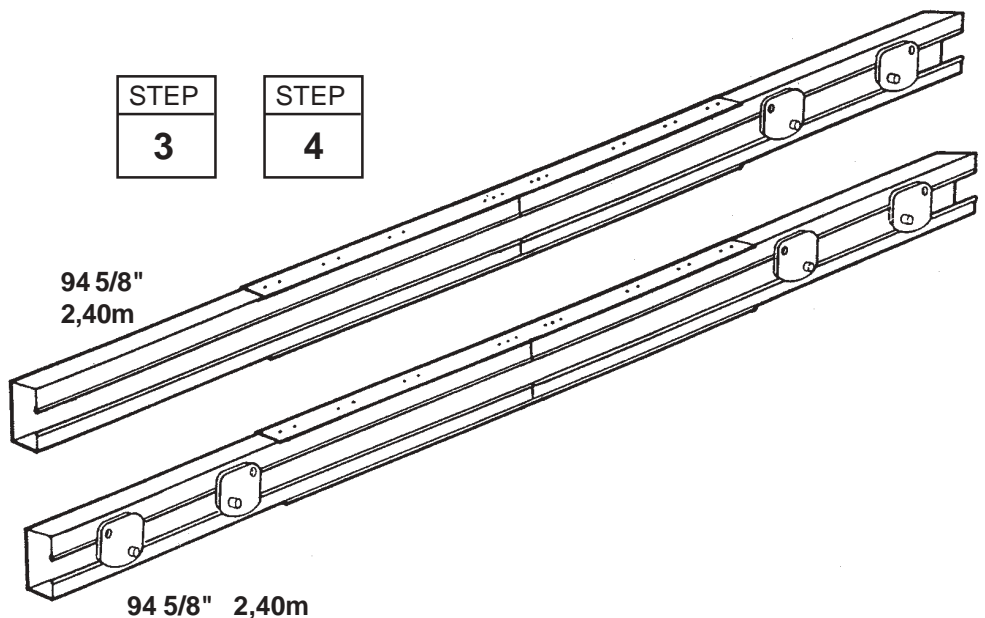
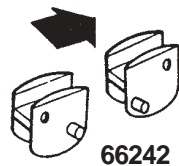
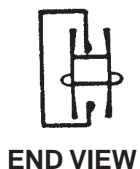

Step 5

B18

● Parts Needed For ● Floor Frame

- Front Floor Assembly (1)
- 8946 Side Floor Frame (2)
- Rear Floor Assembly (1)

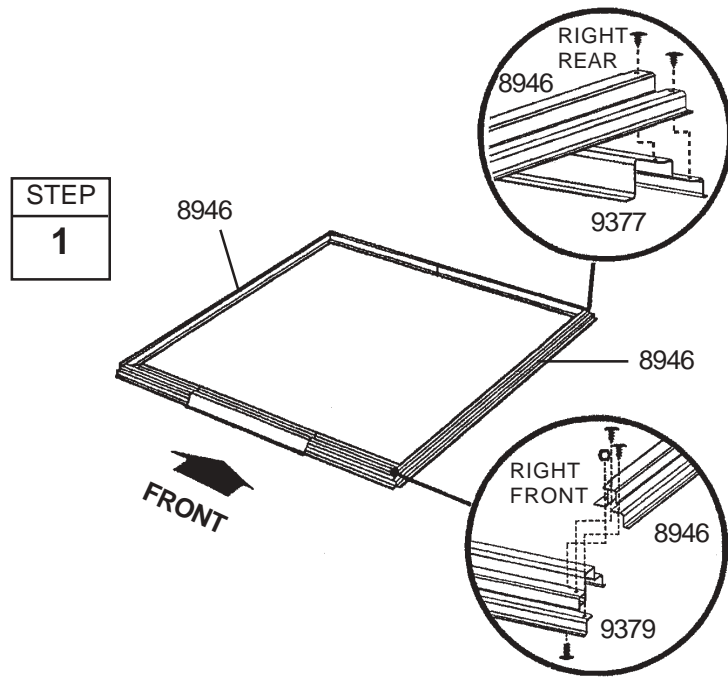

1 Assemble the four corners of the floor frame using two screws at each corner as shown. At the front corners fasten bolts through from the bottom with nuts on top.

2 Measure the floor frame diagonally. When the diagonal measurements are equal, the floor frame is square.

When Diagonal Measurements are Equal the Floor Frame is Square.

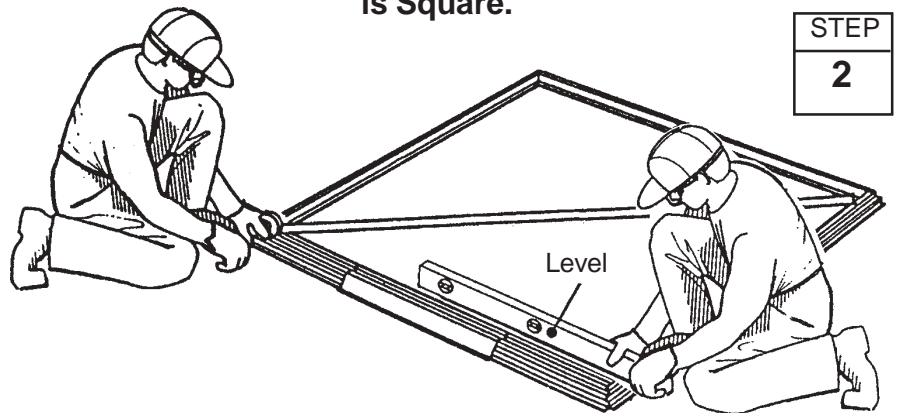

NOTE

If using a wood platform or concrete slab do not fasten the floor frames to your base at this time. You will anchor the building after it is erected.

NOTE

If you have purchased a Floor Frame Kit you need to install it at this time.

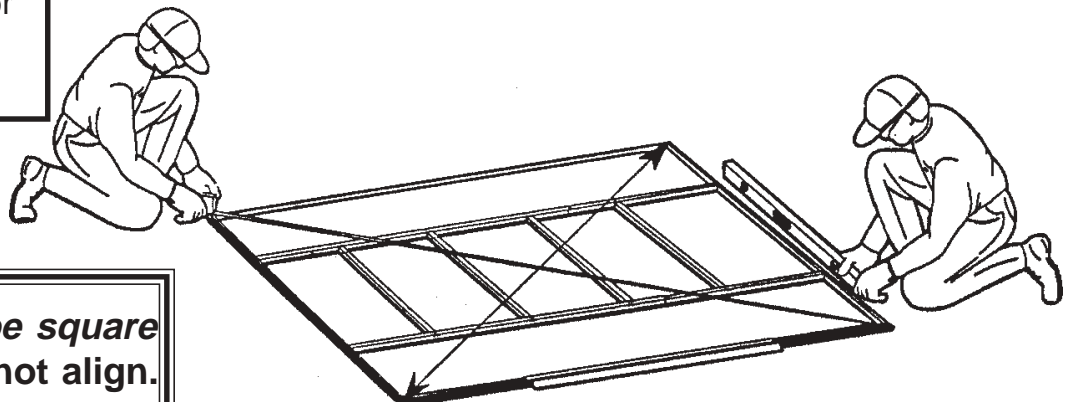

The floor frame *must be square and level* or holes will not align.

Step 6

B19

● Parts Needed For ● Corners

- 9380 Front Corner Panel (2)
- 9384 Rear Corner Panel (2)

NOTE

The remainder of the building assembly requires many hours and more than one person. Do not continue beyond this point if you do not have enough time to complete the assembly today. A partially assembled building can be severely damaged by light winds.

Each screw and bolt in the wall requires a washer.

1 Position the **rear corner panels** at the rear corners, as shown. The widest part of each rear corner panel must be placed along the rear of the building. Attach the corner panels to the floor frame with four screws.

2 Position a **front corner panel** at the corner of the floor frame as shown. The widest part of each front corner panel must be placed along the front of the building. A small gap will exist between front corner panel and ramp. Fasten the corner panel to the floor frame with three screws.

NOTE

Be careful to install the correct panel in each position as shown

3 Double-check the part numbers of the wall panels, before proceeding.

The floor frame *must be square and level* or holes will not align.

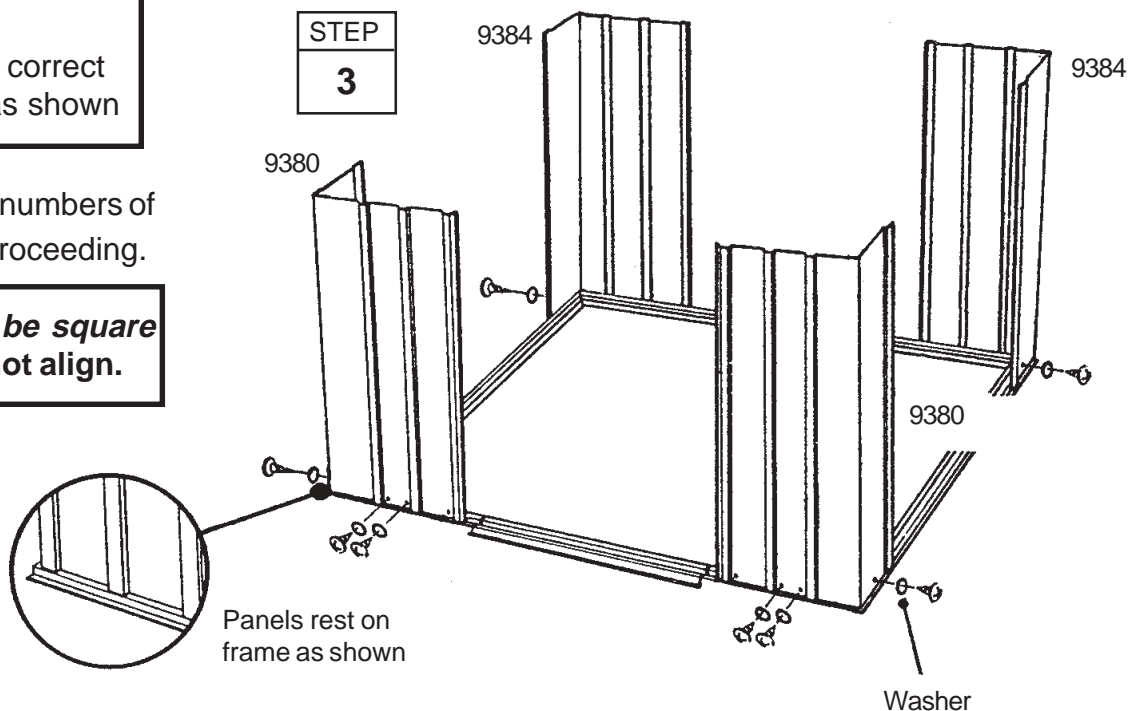
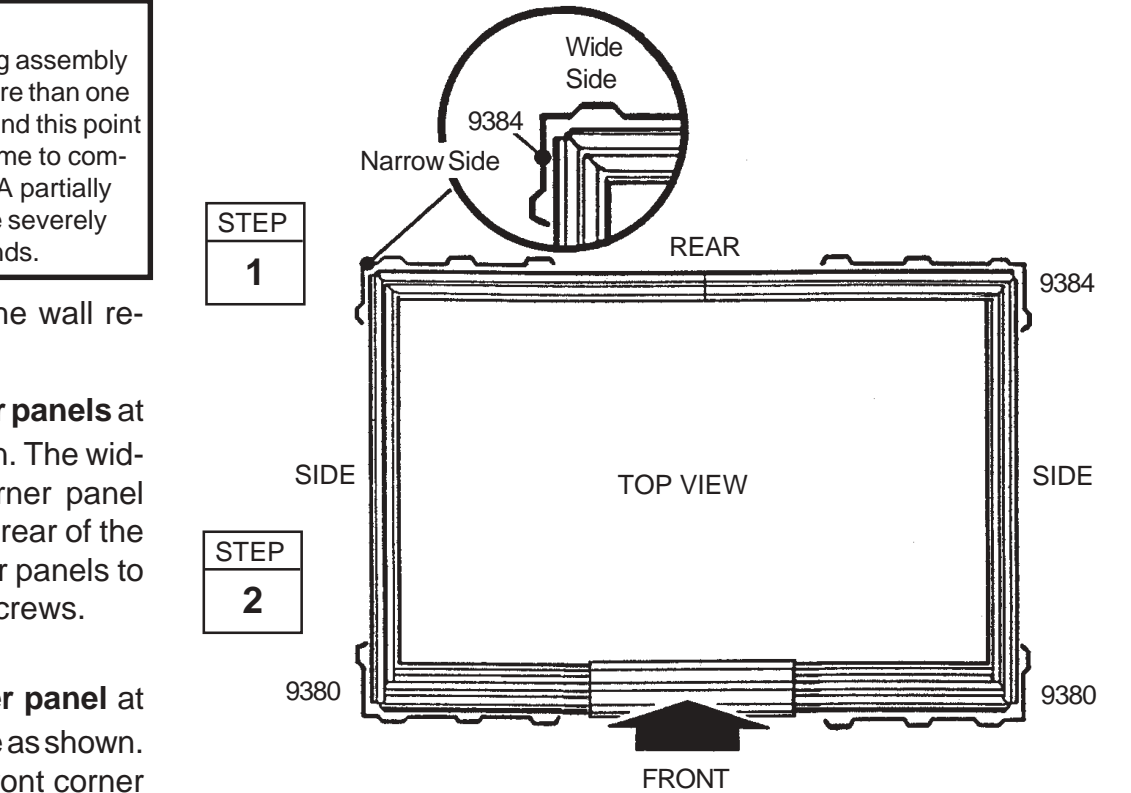

Step 7

B20

● Parts Needed For ● Frames

- Door Track Assembly (1)
- Rear Wall Angle Assembly (1)
- 8476 Side Wall Angle (2)
- Rear Wall Channel Assembly (1)
- 9920 Side Wall Channel (2)

The main frame pieces give rigidity to the side walls and provide a surface for attaching the gables which support the roof.

1 Fasten the **rear wall angle assembly** across the inside top of the rear wall using screws.

2 Fasten the **rear wall channel assembly** across the middle of the rear wall using screws.

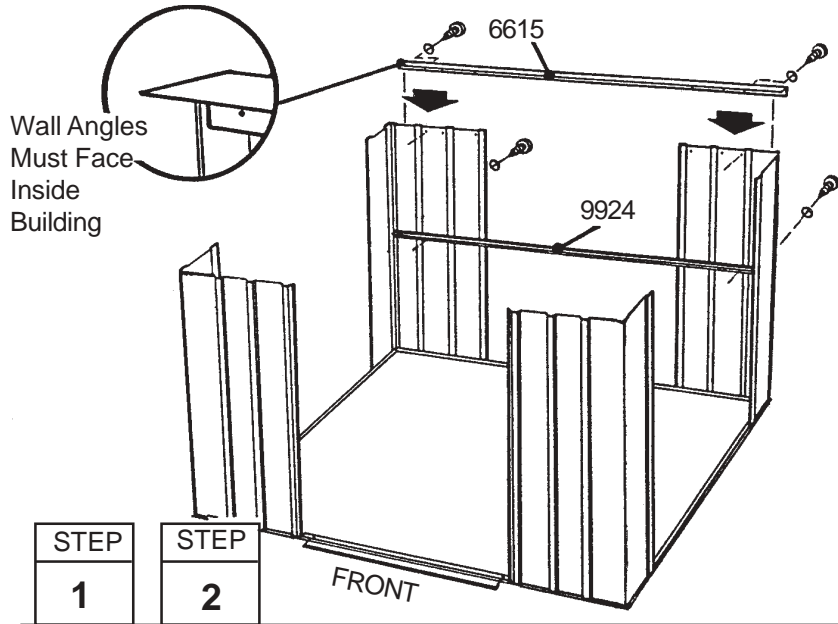

3 Fasten the **side wall angles** across the inside top of the side panels using screws. Side wall angles must overlap rear wall angle in corners.

4 Fasten the **side wall channels** across the middle of the side panels using screws. Fasten overlaps in rear corners with screws.

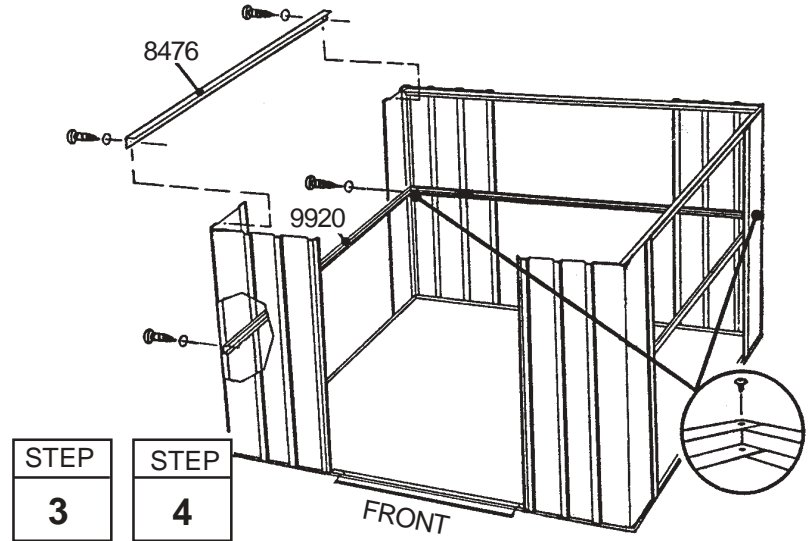

5 Fasten the **door track assembly** (holes on top) across the top of the front wall panels using screws. See the figure.

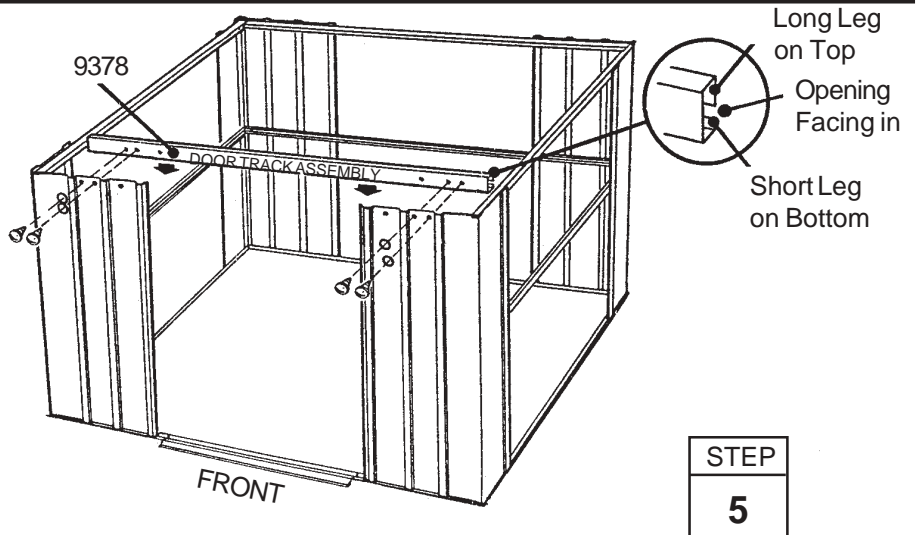

Step 8

B21

● Parts Needed For ● Wall Panels

- 8995 Wall Panel (4)
- 9363 Wall Panel (2)

The wall panels come in two widths. Each wall panel has a crimped rib on one side. The crimped rib should go under the rib of the panel that follows it.

1 Locate all of the **wall panels** and set each one alongside the building.

2 Be sure that you have the correct panels in each position. Do this by overlapping the panels and determining if the holes line up with the holes in the frame.

3 Fasten the wall panels at the top and bottom with screws.

4 Fasten the center of each panel to the wall channel with screws. Fasten overlapping ribs using a bolt and nut with two screws.

5 When you have attached all wall panels in the correct positions, the building will look like this.

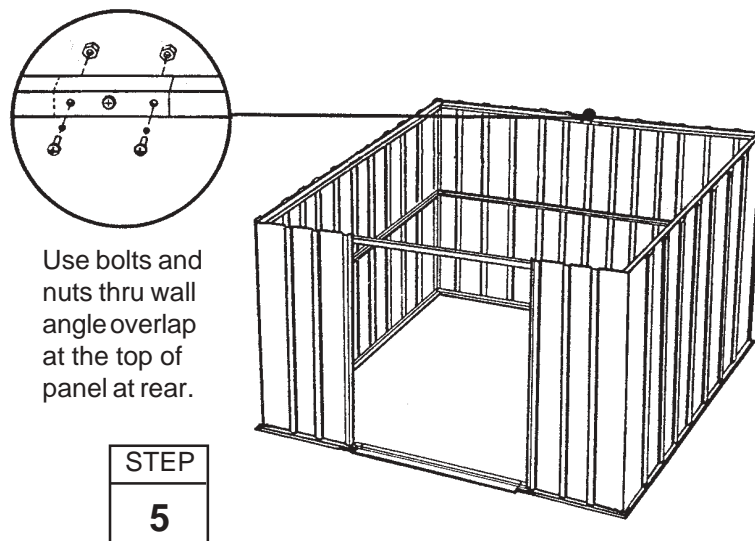
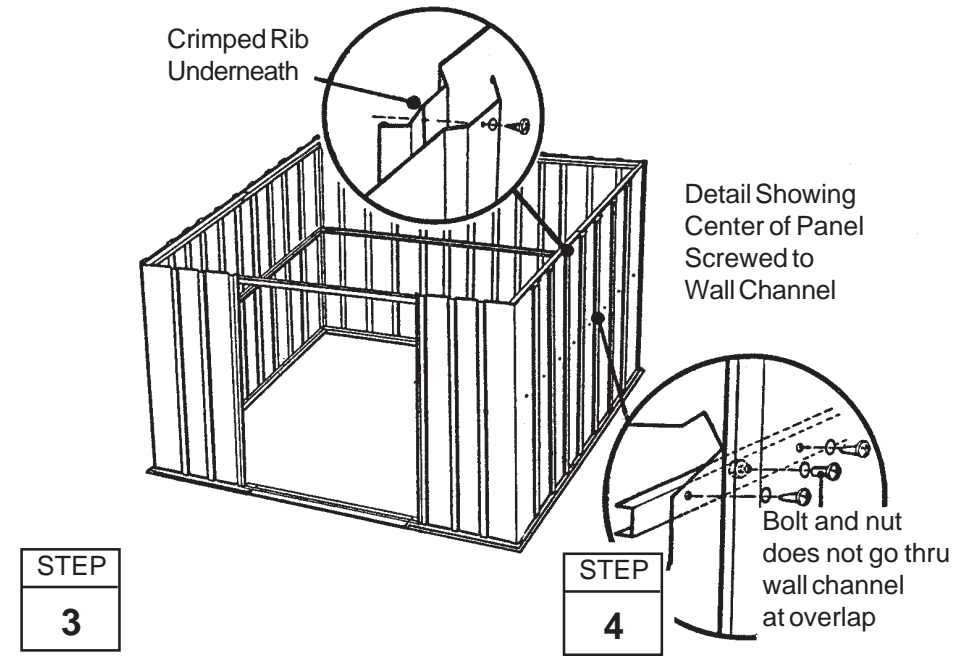
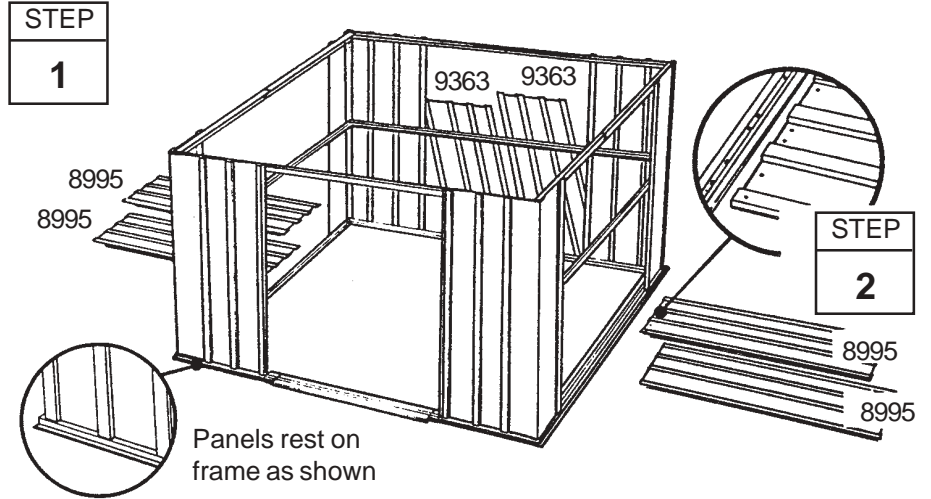

Step 9

B22

● Parts Needed For ● Door Jamb

● 9900 Door Jamb (2)

The door jambs reinforce the door opening and provide an attractive trim. Follow these steps for both door jambs.

1 Fasten a **door jamb** to the front panel with three bolts, nuts and acorn nuts, as shown. Push a **plug** into hole at center of jamb, closest to door opening.

2 Fasten the top of the door jamb to the door track with two screws. Do the same for the bottom into frame.

Repeat steps 1 through 2 for the *opposite* door jamb.

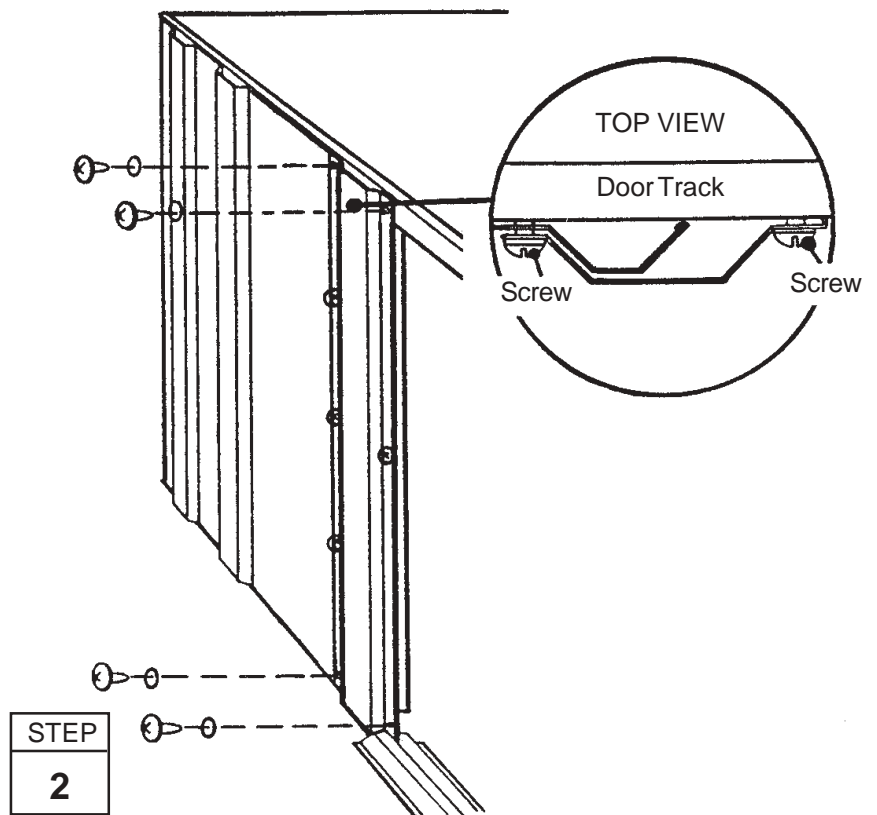
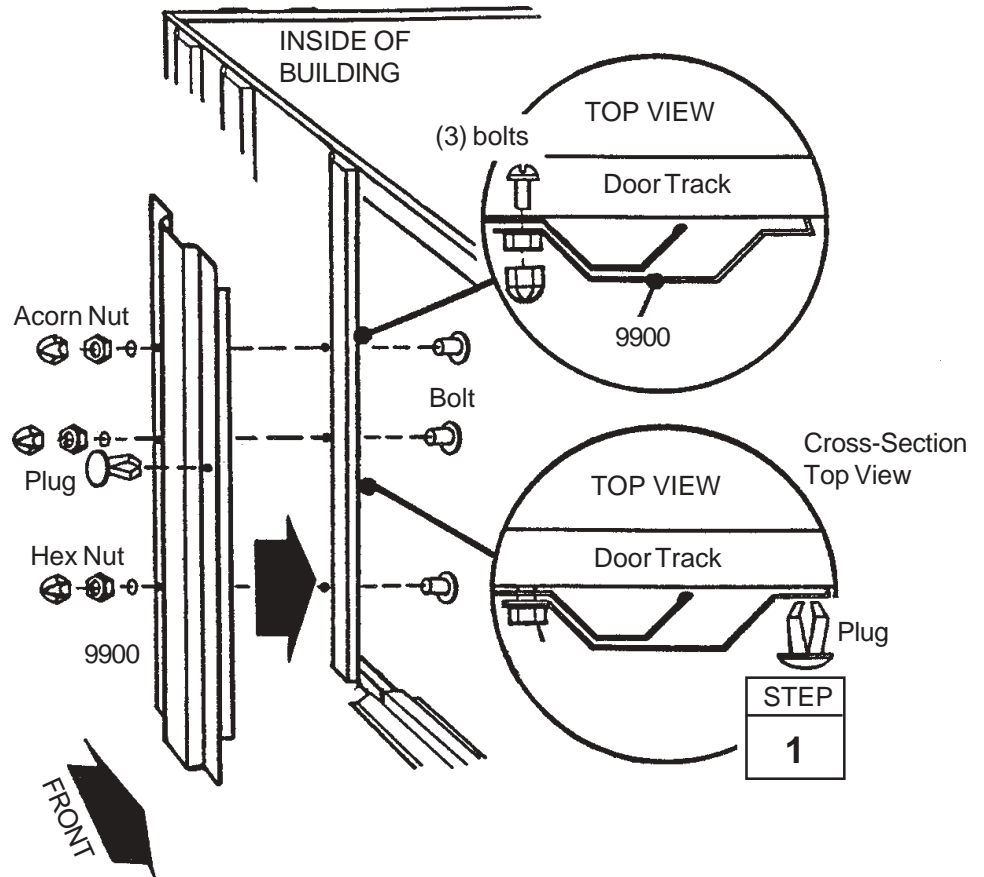

Step 10

B23

● Parts Needed For ● Gable Assemblies

- 7906 Right Gable (2)
- 7907 Left Gable (2)
- 7916 Roof Beam Bracket (4)

The gables go on top of the front and rear walls to support the roof beams.

NOTE

The gables are packed nested together and might be mistaken as one piece. Carefully separate them before continuing.

1 Attach the four **roof beam brackets** to the gables using two bolts, washers and nuts.

NOTE

Mounting leg of bracket must face toward center of gable

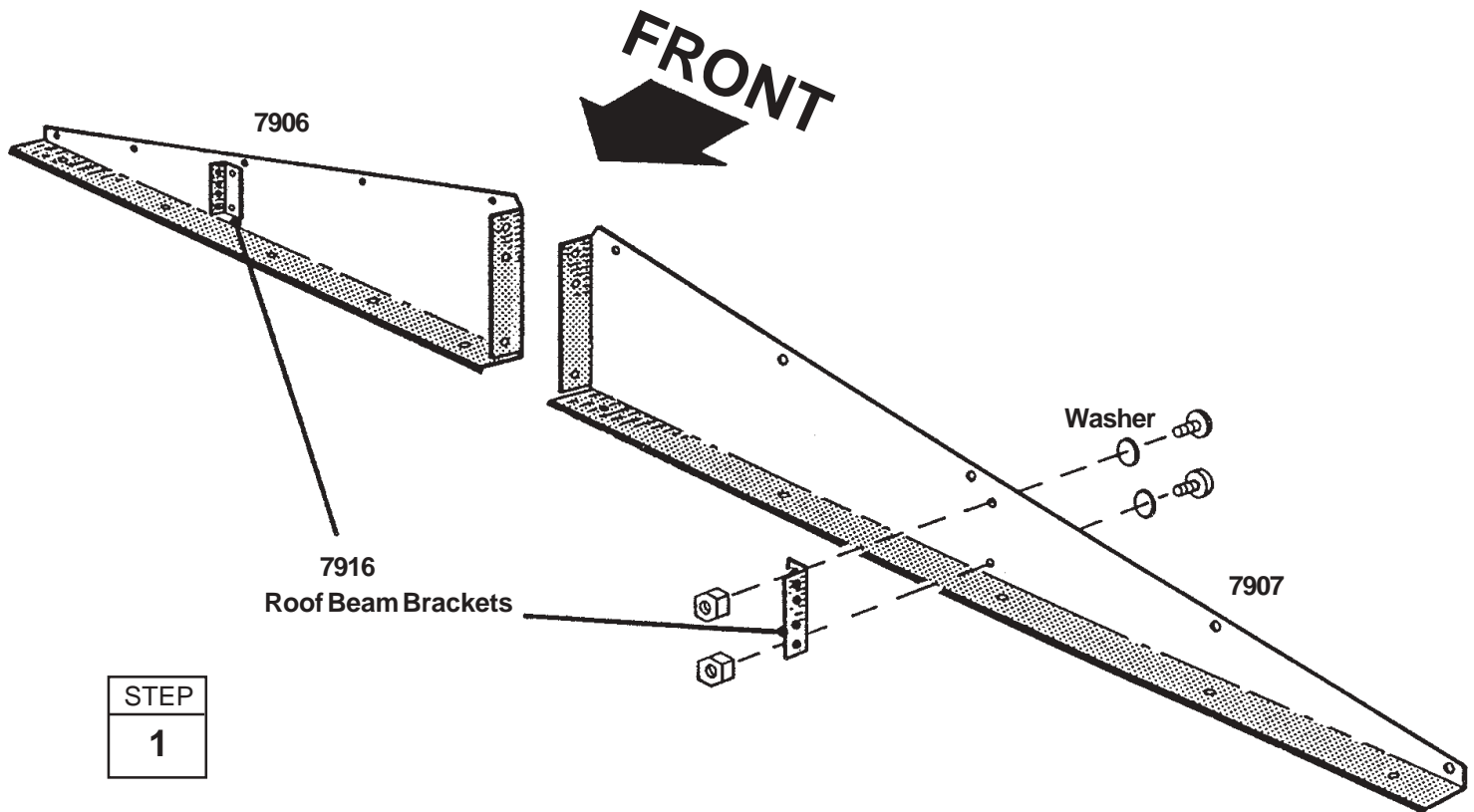

STEP
1

Step 11

B24

● Parts Needed For ● Gables/Braces

- Left Gable Assembly (2)
- Right Gable Assembly (2)
- 6658 Gable Brace (2)

1 Lift and fasten a right and left gable, under angle at corner, to the rear wall angle with screws.

Hint: On the rear gable, use a bolt and nut at the overlapping rear wall angle. On the front gable, leave out 2 screws closest to center gable leg.

2 Join the **left** and **right gables** together with a **gable brace** using bolts and nuts in the bottom two holes *only*.

3 Repeat Steps 1 & 2 for the door track on the front of building, except for the **track supports**, fasten as shown.

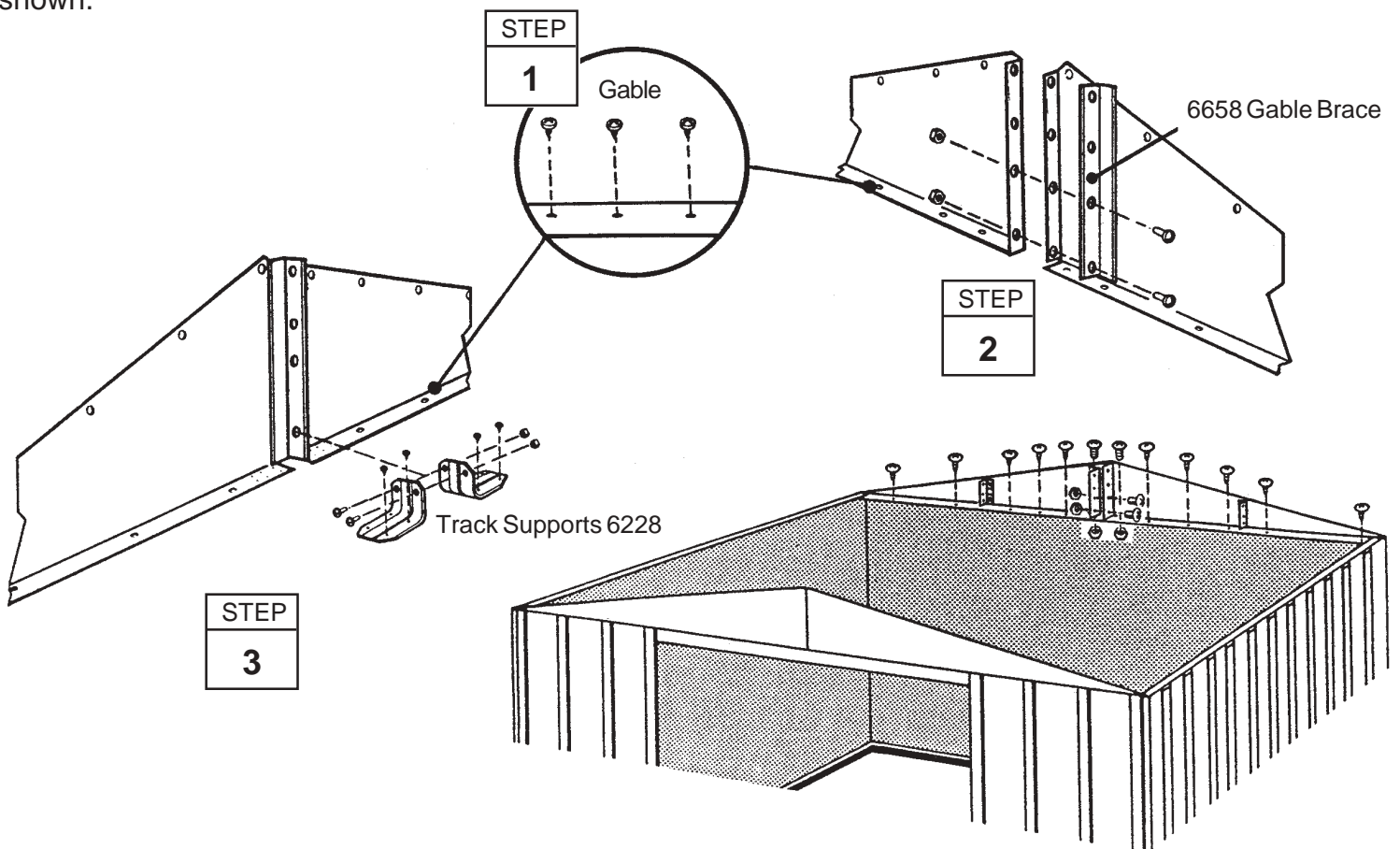
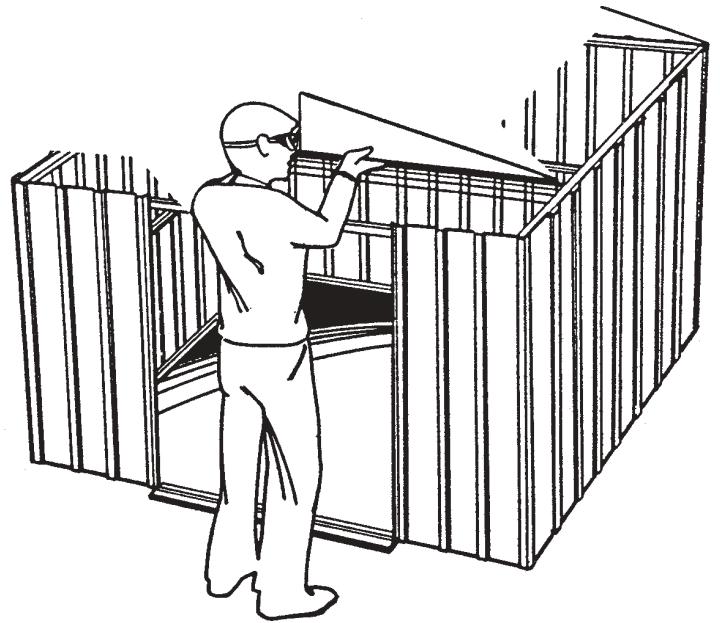

Step 12

B25

● Parts Needed For ● Roof Beams

- Main Roof Beam (1)
- 8474 Roof Beam (2)

1 Fasten the **main roof beam** to the gable brace of the front gable.

2 Fasten the other end of the main roof beam to the gable brace of the rear gable.

3 Fasten the remaining **roof beams**, *small holes on top*, as shown using bolts and nuts.

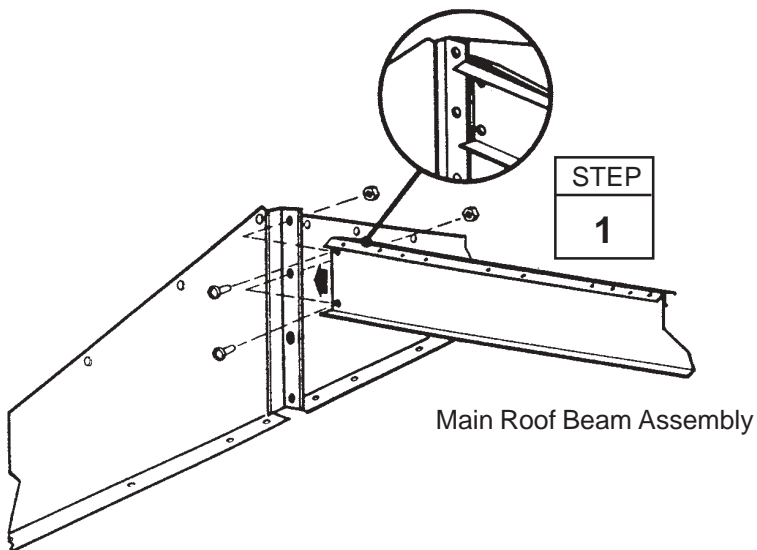
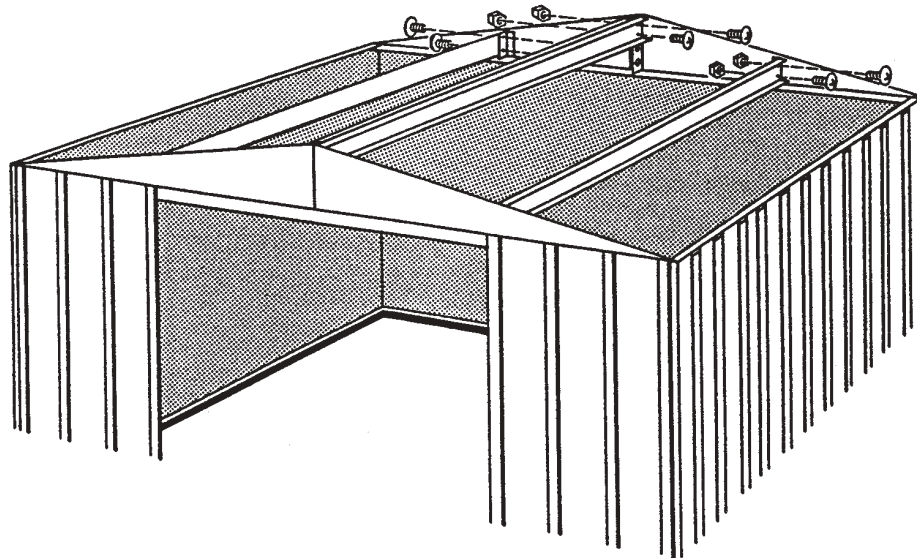
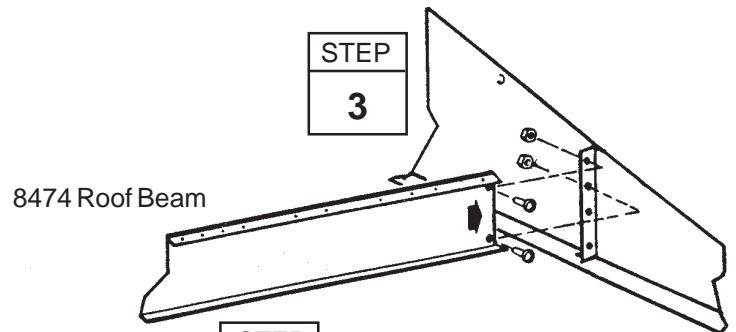

Step 13

B26

● Parts Needed For ● Right Roof Panel

● 8466 Right Roof Panel (1)

STEP
1

Installing the roof panels is best done with a step ladder. Begin installing roof panels at the back right corner of the building. Each screw and bolt in the roof requires a washer.

NOTE

Measure the building diagonally again and make adjustments to make sure the building is square and level. This will make the roof panels fit better, and holes will align. Don't anchor the floor frame.



FRONT

NOTE

If a **Roof Beef-Up Kit** was purchased, assemble prior to attaching the roof panels.

STEP
2

1 Locate the roof panels by their numbers. *Note the sequence and position they are to be installed.*

2 Position the **right roof panel** at the back right corner and fasten to the gable with 5 bolts and nuts and roof beams using 2 screws. *Do not fasten the lower end of the panel to the side wall angle at this time.*

Hint: Attach fasteners in order shown in diagram.

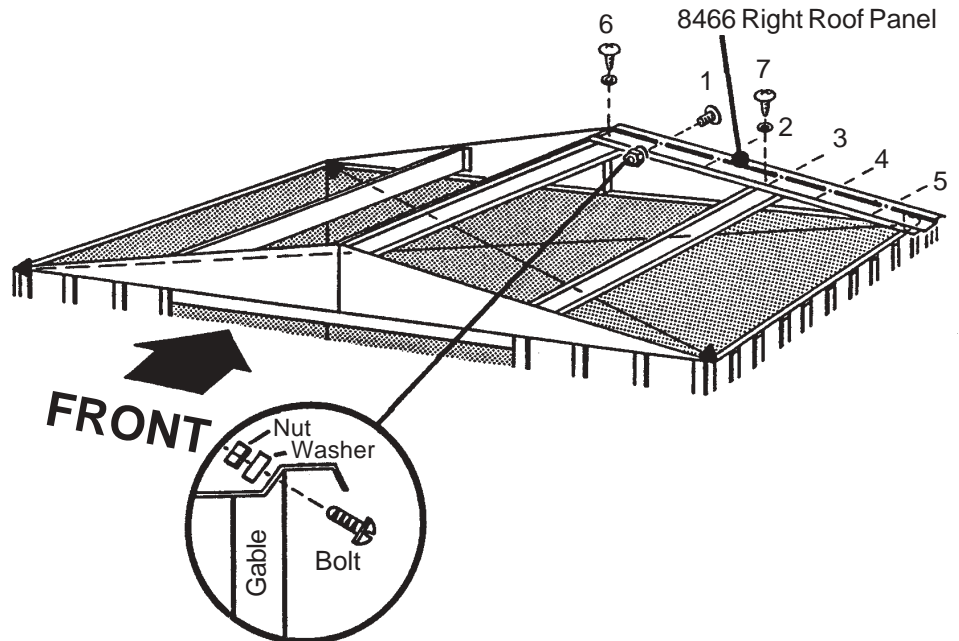

Step 14

B27

● Parts Needed For ● Roof Assembly

- 8467 Left Roof Panel (2)
- 7875 Roof Panel (4)
- 8466 Right Roof Panel (1)

1 Install a **left roof panel** at the left rear and right front corner of the roof. Install a **right roof panel** at the left front corner of the roof.

2 Cut 2 short 2" (5cm) strips off the roll of **weather stripping tape**, and put them aside. Cover the joint at the peak with weather stripping tape. Unroll the tape and press it down over the opening at the ridge as you install each roof panel. Do not cut the tape at this time.

3 Install 4 **roof panels** in the sequence and positions shown on previous page. *Do not fasten the lower end of the panels to the side wall angles at this time.* Continue weather stripping the ridge opening. Fasten roof panel overlaps not used for ridge cap (roof center). Cover the head of bolt with the 2" (5cm) piece of weather stripping tape.

STEP
1

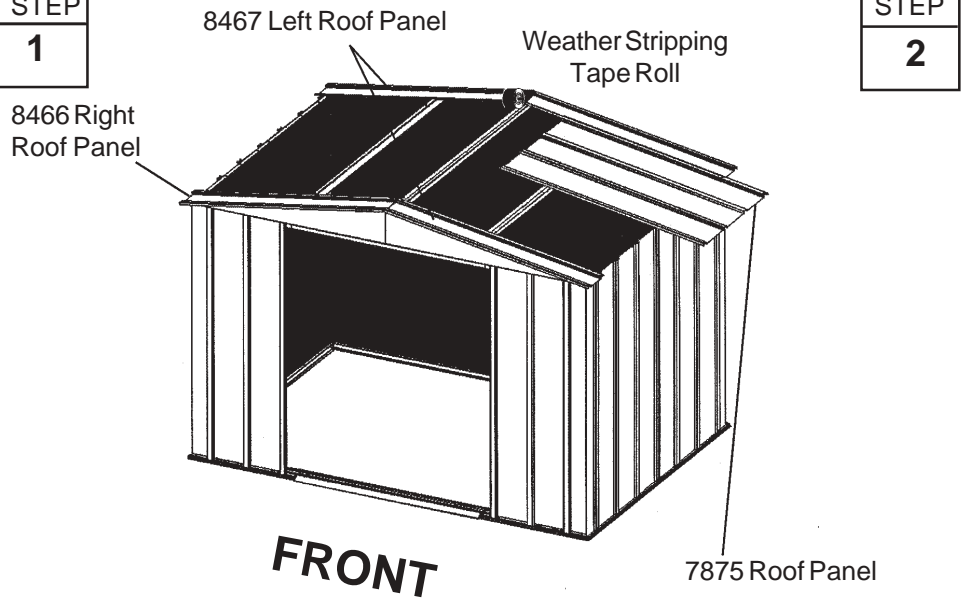

STEP
2

NOTE
Narrow roof panel crimped rib is overlapped by wide rib of adjacent panel where possible.

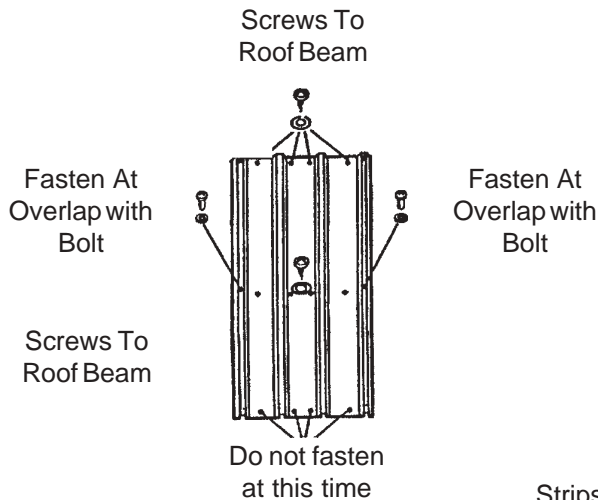

STEP
3

NOTE
If roof beam holes do not line up with the roof panel holes, shift the building from left to right. If this does not help, your building may not be level. Shim the corners until holes line up.

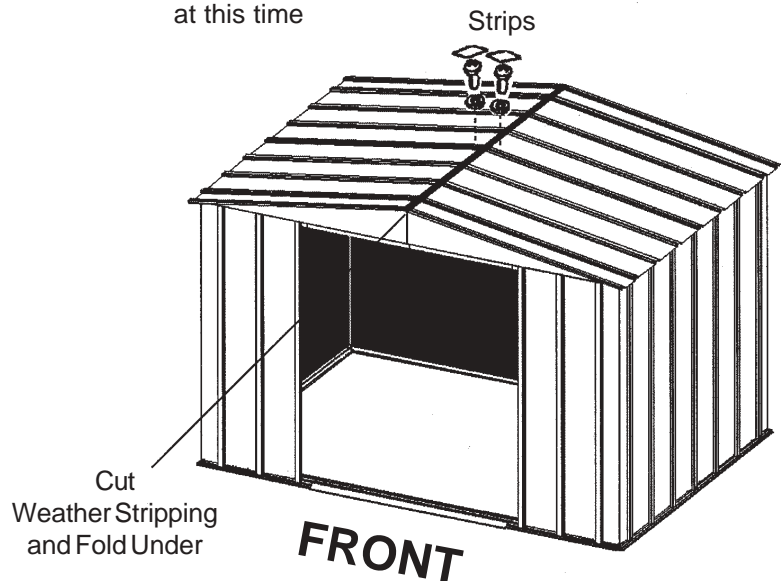

Step 15

B28

● Parts Needed For ● Ridge Cap

● 8461 Ridge Cap (1)

1 Install the **ridge cap** on the completed roof section using bolts and nuts. Do not fasten the ends of the ridge cap at this time.

2 Fasten the lower end of the panels to the side wall angles using screws and washers.

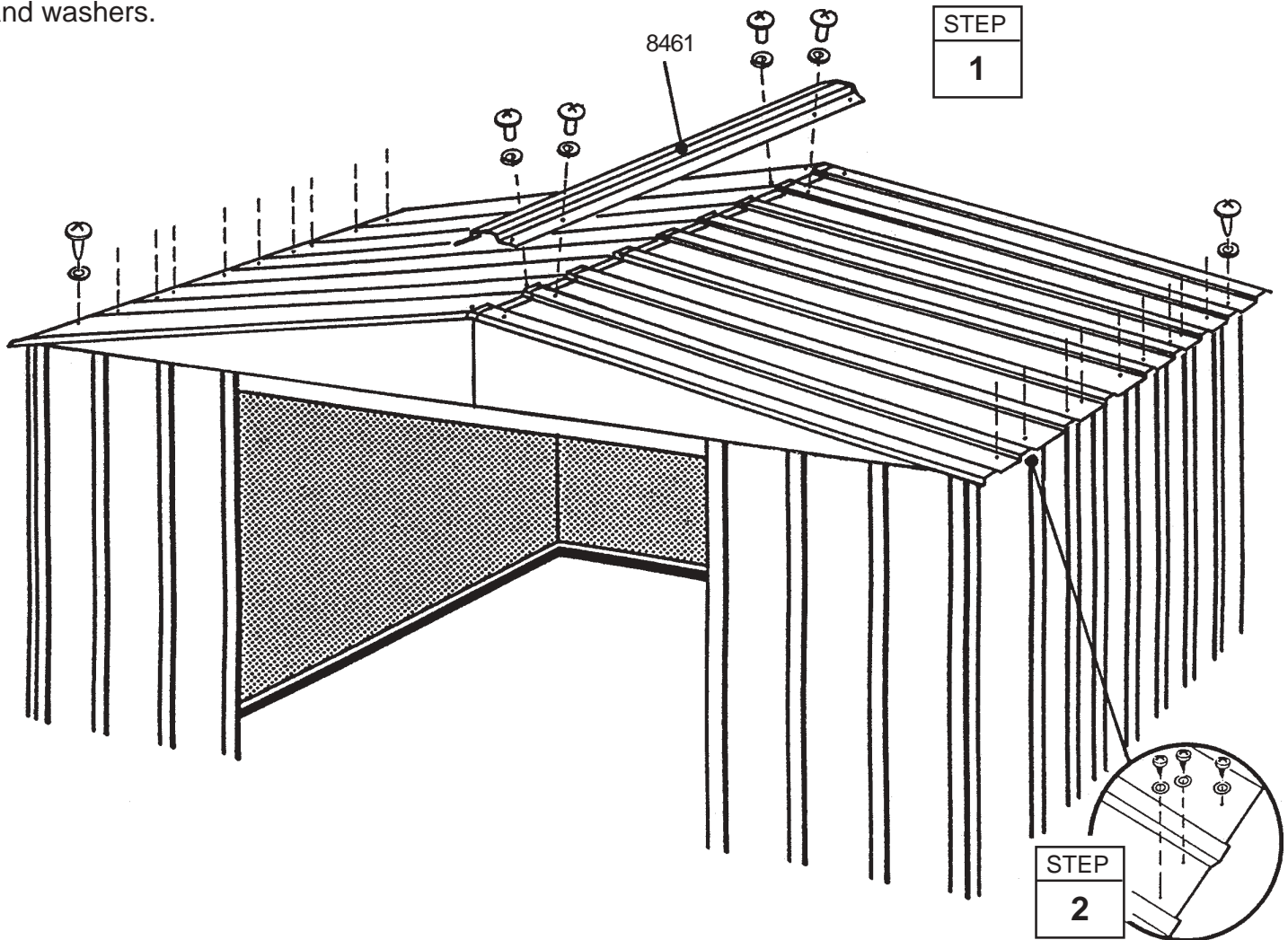

Step 16

B29

● Parts Needed For ● Roof Trim

● 8482 Side Roof Trim (2)

1 Attach the **side roof trim** to the lower end of the roof panels on each side of the building using screws at each panel overlap.

2 Using your thumb and index finger, overbend the bottom flange of the side roof trim and roof panel rib at the corner inward enough so the right and left roof trim caps fit onto right and left corners.

3 Fasten the roof trim caps to the side trim using a screw.

4 Fasten the roof panel ribs, **peak caps** and ridge cap together using bolts and nuts.

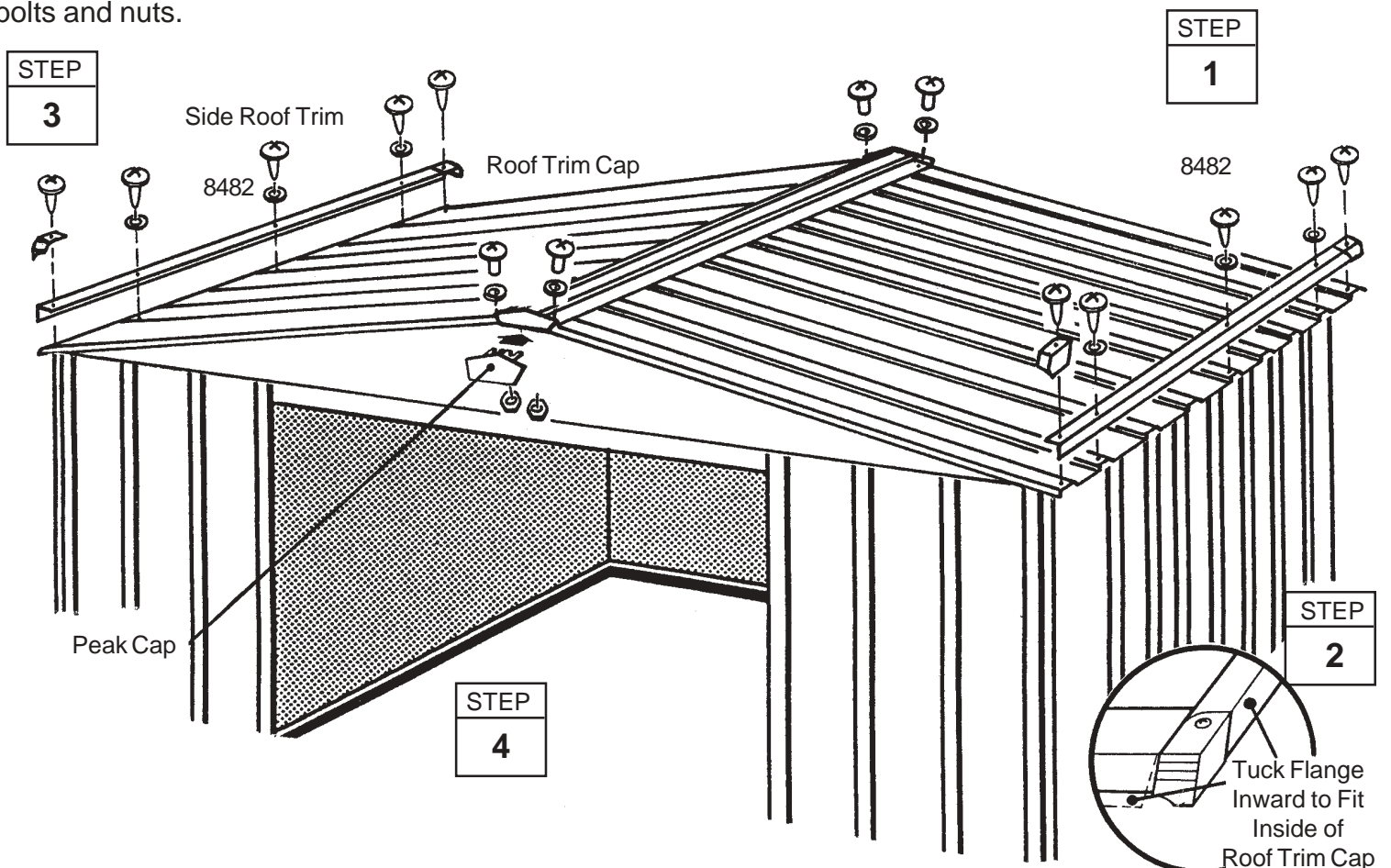

Step 17

B30

● Parts Needed For ● Door Assembly

- 9358 Right Door (1)
- 9359 Left Door (1)
- 6622 Horizontal Door Brace (4)
- 9355 Vertical Door Brace (2)

The steps on this page tell how to assemble the right door. You will perform exactly the same procedures for the left door. Each bolt and screw in the door requires a washer. Proceed as follows:

1 Attach the **handle** to the **door** with 2 bolts and nuts as shown.

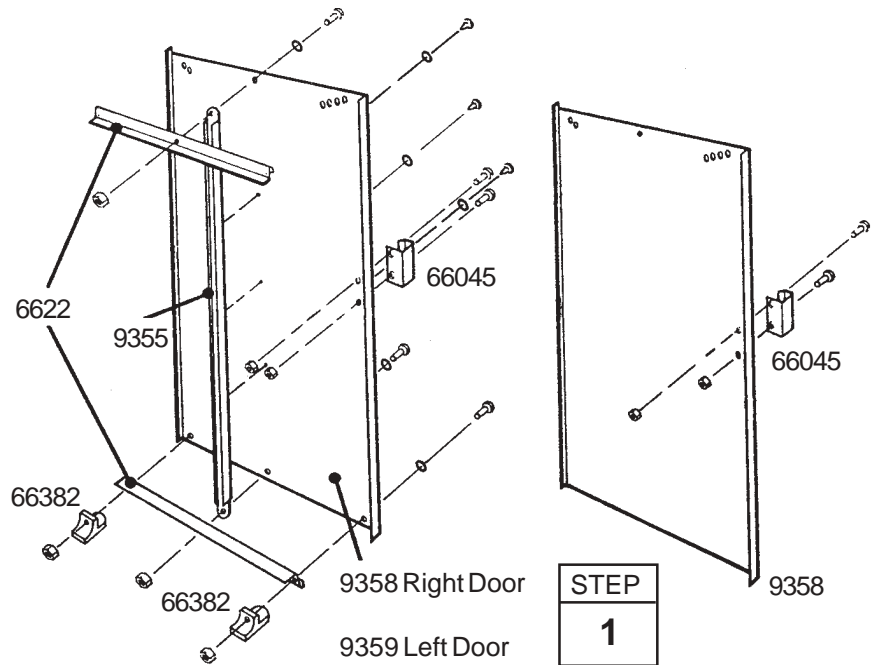

2 Hold the **vertical door brace** against the center of the inside surface of the door and turn the screw to hold the vertical door brace in place. Fasten to door above and below center connection using 2 screws.

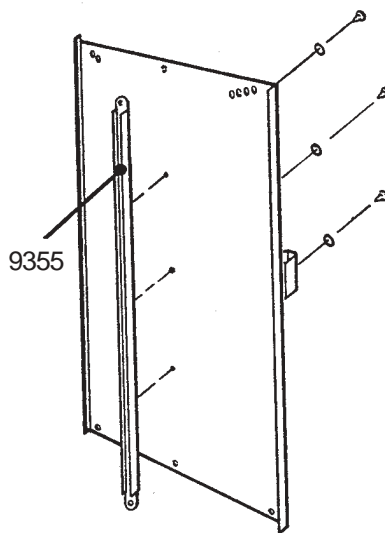

STEP
2

3 Put a **horizontal door brace** onto the top edge *and* bottom edge and fasten with 1 bolt in the center.

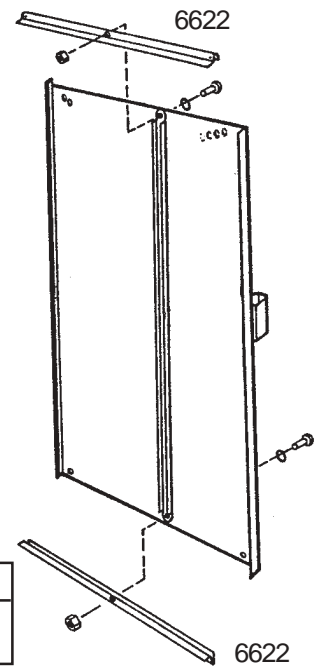

STEP
3

4 Attach the **lower door guides** as shown.

5 Repeat steps 1 through 4 for the **left door**.

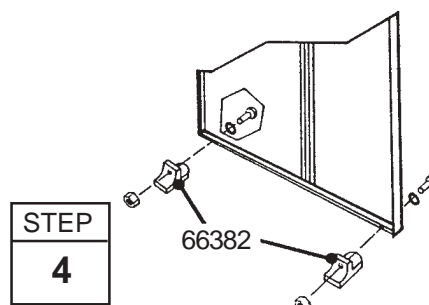

STEP
4

END VIEW
SHOWING:

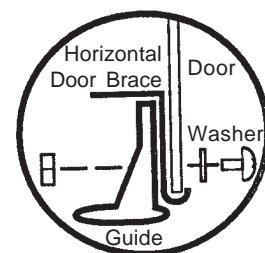

Step 18

P31

● Parts Needed For ● Door Installation & Adjustment

- Right Door Assembly (1)
- Left Door Assembly (1)

1 From inside the building, put the bottom of the right door assembly (on your left when you are inside the building) behind door jamb into the front frame track.

2 Position the top of the door so that the holes in the door line up with the holes in the door slides.

3 Fasten the door to the door slides using a #10Bx1/2" screw.

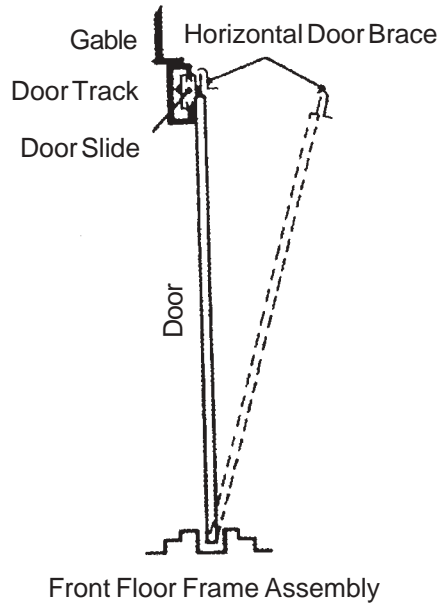

3 Fasten the door to the door slides using a #10Bx1/2" screw.

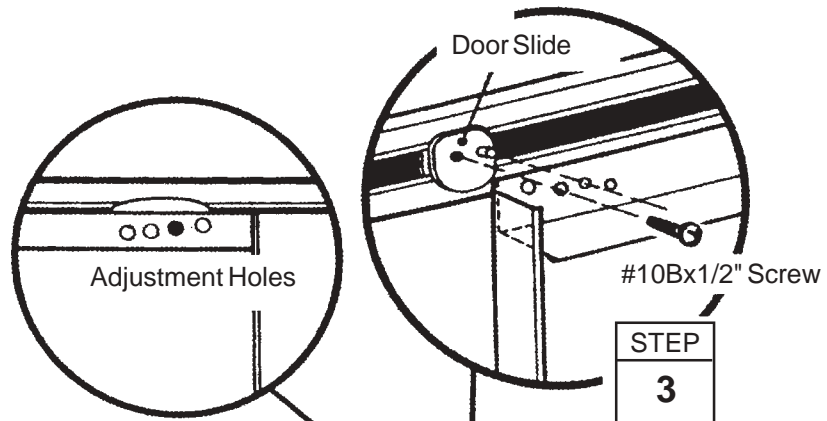

4 Repeat steps 1 through 3 for the left door.

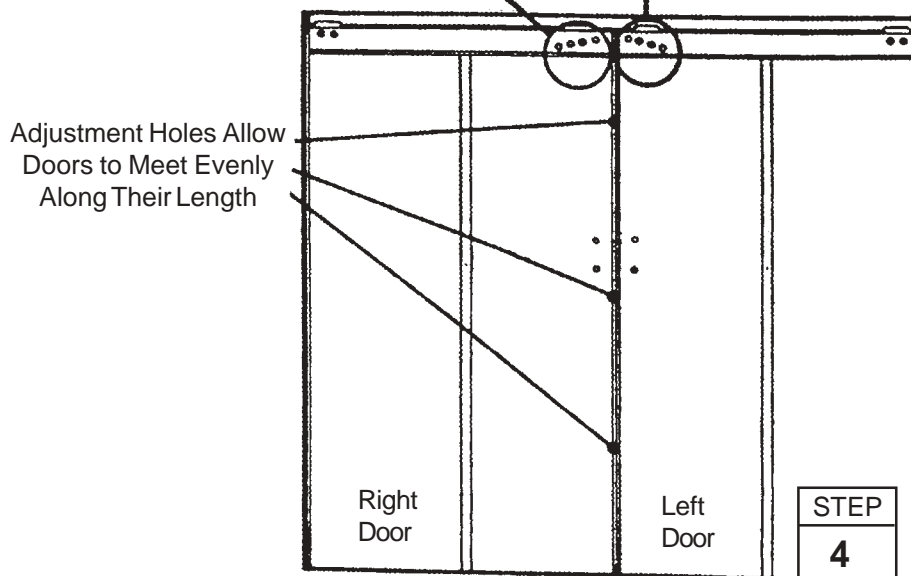

EN86-A
NP86

HM86-A
NW86-A

HM86M
SA86-A

MN86-A
VN86-A

B32

SOME FACTS ABOUT RUST

Rusting is a natural oxidizing process that occurs when bare metal is exposed to moisture. Problem areas include screw holes, unfinished edges, or where scrapes and nicks occur in the protective coating through normal assembly, handling and use. Identifying these natural rusting problem areas and taking some simple rust protection precautions can help to stop rust from developing, or stop it quickly as soon as it appears.

1. Avoid nicking or scraping the coating surface, inside and out.
2. Use all the washers supplied. In addition to protecting against weather infiltration, the washers protect the metal from being scraped by the screws.
3. Keep roof, base perimeter and door tracks free of debris and leaves which may accumulate and retain moisture. These can do double damage since they give off acid as they decay.
4. Touch up scrapes or nicks and any area of visible rust as soon as possible. Make sure the surface is free of moisture, oils, dirt or grime and then apply an even film of high quality touch-up paint.